

Membrane Nitrogen Generator



Nitrogen concentration of **99.9% or more**, with only a compressed air supply*1

*1 The nitrogen concentration refers to the total concentration within the compressed air, which contains argon, CO₂, water vapor, and other components in addition to nitrogen and oxygen.

- A total of 8 model variations available
- Compact and easy to use at point of use
- Outlet side compressed air purity class 2 (Humidity)*2

*2 When the inlet side compressed air purity class is ISO 8573-1:2010 [1:6:1]

Variations (For details, refer to page 2.)

	Model	Type	Outlet nitrogen-enriched air flow rate*3 [L/min (ANR)]
Single Membrane Module	NMG50A-04N1	400 type	6.0
	NMG50A-08N1	800 type	20
	New NMG50A-13N1	1300 type	36
Double Membrane Module	New NMG50A-1308	1300 + 800 type	44
	New NMG50A-13N2	1300 + 1300 type	56
	New NMG50B-08N2	800 type x 2	40
Manifold	New NMG50B-13N2	1300 type x 2	72
	New NMG50B-13N3	1300 type x 3	108

*3 At a nitrogen concentration of 99.9%*1, an inlet air pressure of 0.7 MPa, and an inlet air temperature of 25°C

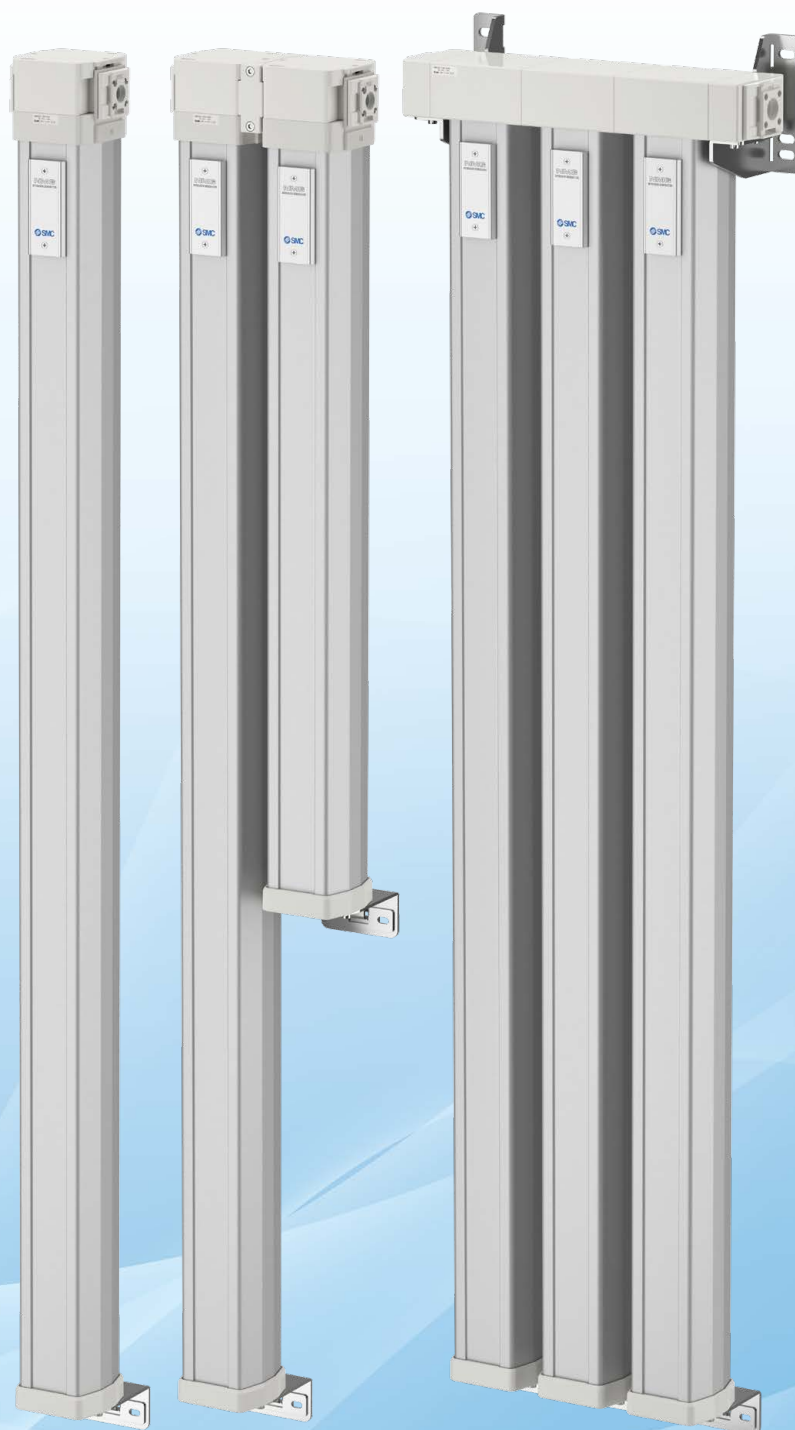

Single Membrane Module

1300 type

Double Membrane Module

1300 + 800 type

Manifold

1300 type x 3

NMG Series



CAT.ES30-29B

Principle of Operation

Product overview

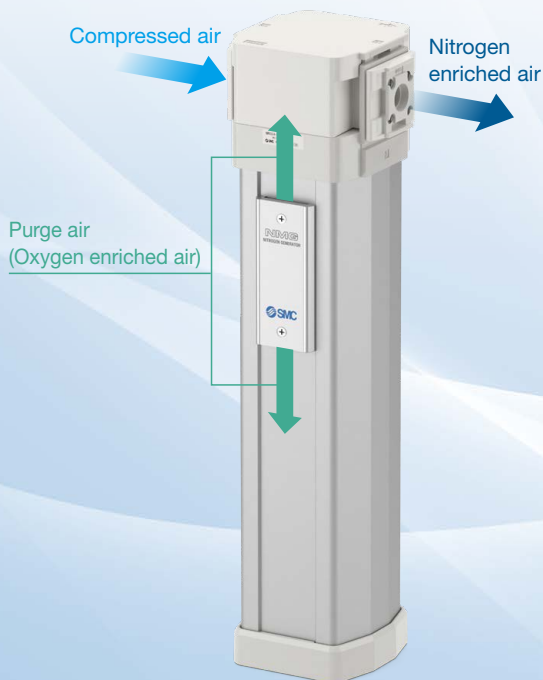

Nitrogen enriched air production

The membrane of the Membrane Nitrogen Generator is made of many hollow fibers which allow Oxygen to easily permeate through the fiber wall, but not Nitrogen.

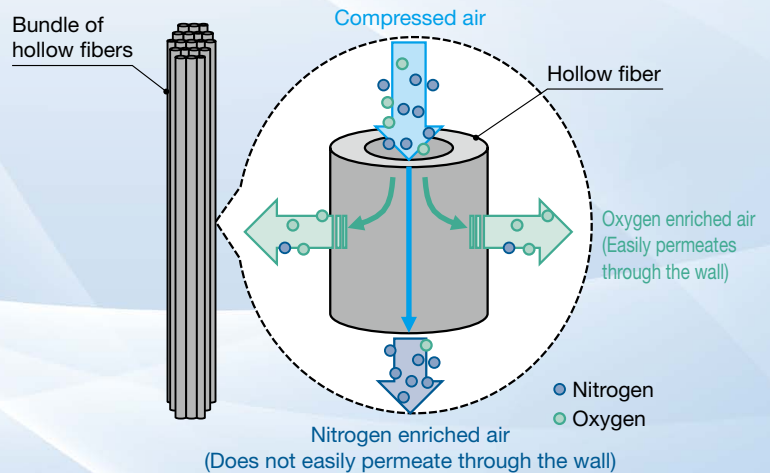

Controlled discharge of purge air

The purge discharge cover can be removed to allow for piping connections^{*1}

*1 Refer to the operation manual before use.



Comparison with nitrogen cylinders

Gas unit price comparison

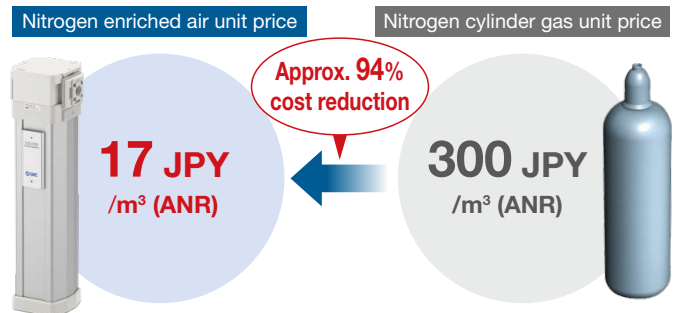

* When the nitrogen concentration is 99.9% and the compressed air unit price is 2.4 JPY/m³

Reduced labor time

- No need for cylinder replacement or gas level checks
- No need to refill nitrogen cylinders

Comparison with the PSA (pressure swing adsorption) method

Comparing with the PSA method, which uses pressure fluctuations to separate and purify gas

- Space saving
- Not subject to pressure vessel regulations
- No regular maintenance required since chemical adsorbents are not used
- Compared to the PSA method, which requires solenoid valves and control devices, it can be used with just a supply of compressed air without the need for a power source.

Modular Connection Type

- Space saving, Reduced piping labor
 - A variety of compatible devices
- Related Products **p. 5**
- Modular connection examples **p. 21**



Flow Rate Variations

Note The nitrogen concentration of nitrogen-enriched air obtained from the membrane nitrogen generator represents the total concentration of components other than oxygen in the compressed air. Compressed air contains argon, CO₂, water vapor, and other components in addition to nitrogen and oxygen.

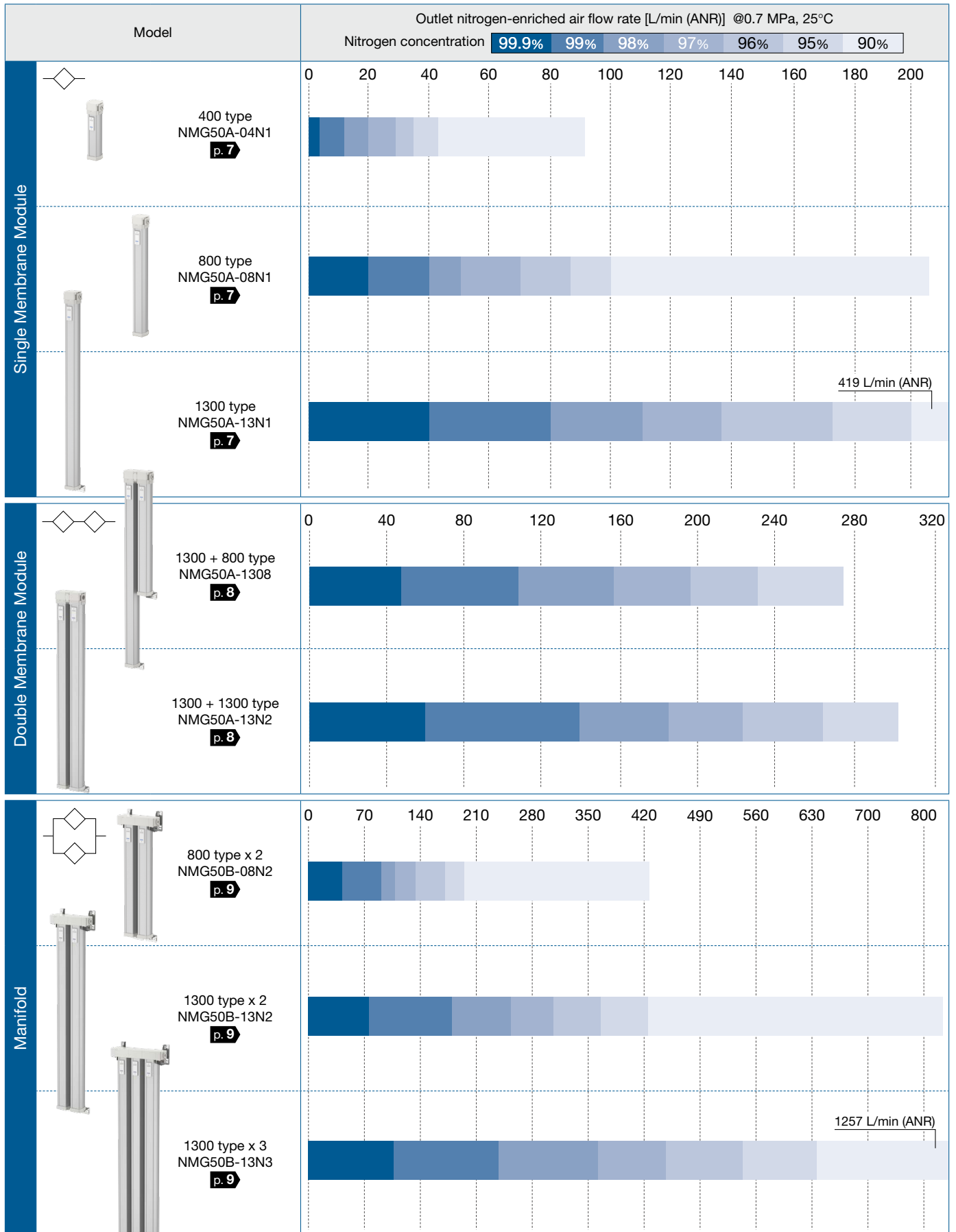

* Refer to pages 13 and 14 for details on the outlet nitrogen-enriched air flow rate.

Application Examples

UV emitters/UV printer

UV steriliser/Oxygen inhibition suppression

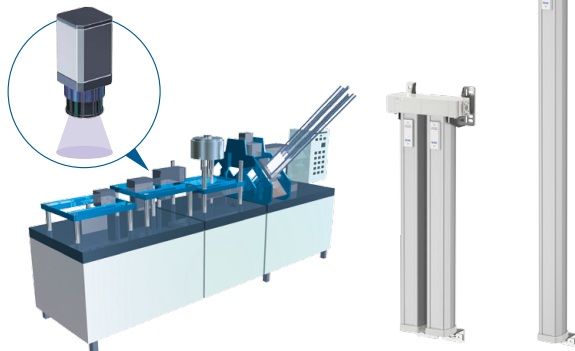

Outlet nitrogen-enriched air flow rate [L/min (ANR)]*1	
Double membrane manifold 800 type x 2	Single membrane module 1300 type
40	36

Molding machine

Hopper, oxidation prevention and suppression of black spots in injection area



Outlet nitrogen-enriched air flow rate [L/min (ANR)]*1	
Double membrane manifold 800 type x 2	Double membrane module 1300 + 800 type
40	44

Process chamber (Annealing, drying, etc.)

Exhaust line
Atmospheric pressure nitrogen replacement
(Reduction of residual oxygen, etc.)

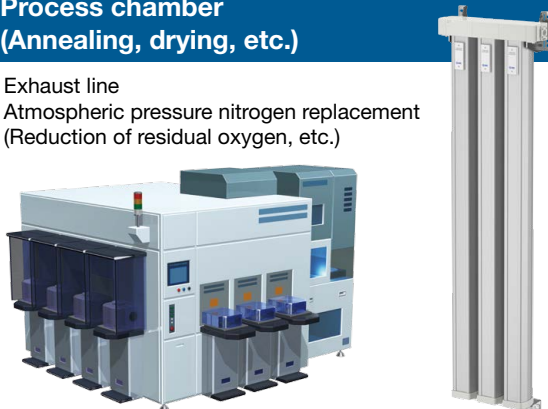

Outlet nitrogen-enriched air flow rate [L/min (ANR)]*1	
Triple membrane manifold 1300 type x 3	
108	

3D printer (Resin, light source)

Discoloration and black spot suppression in EG resin
Oxidation suppression for the laser transmission unit



Outlet nitrogen-enriched air flow rate [L/min (ANR)]*1	
Single membrane module 400 type	Double membrane module 1300 + 1300 type
6.0	56

Filling machine

UV laser, gas injection for filling (N₂, CO₂)

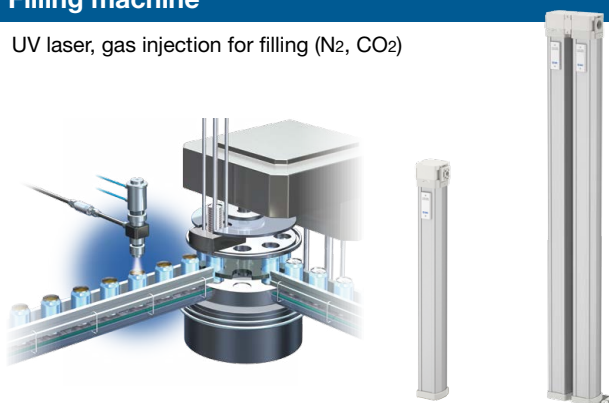

Outlet nitrogen-enriched air flow rate [L/min (ANR)]*1	
Single membrane module 800 type	Double membrane module 1300 + 1300 type
20	56

*1 The outlet nitrogen-enriched air flow rate shown on this page is based on an outlet nitrogen concentration of 99.9%. Be sure to use the product with an outlet nitrogen concentration suitable for each device.

* For selection, refer to the outlet nitrogen-enriched air flow rate and the outlet nitrogen concentration on pages 13 and 14.

Application Examples

Analytical equipment (Protein analysis device, etc.)

Laser for regenerative medicine (bioreactor), Reagent stage chamber

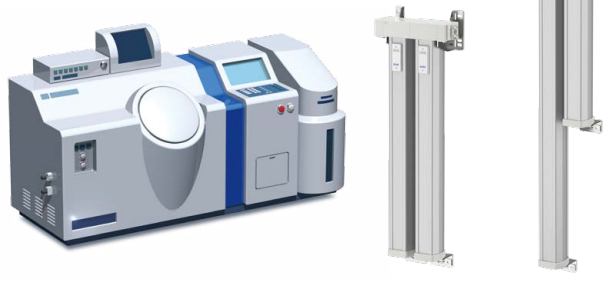

Outlet nitrogen-enriched air flow rate [L/min (ANR)]*1	
Double membrane manifold 800 type x 2	Double membrane module 1300 + 800 type
40	44

Automatic soldering machine

UV laser annealing defects and oxidation suppression



Outlet nitrogen-enriched air flow rate [L/min (ANR)]*1	
Single membrane module 400 type	Single membrane module 800 type
6.0	20

Fiber laser

Assist gas for laser cutting

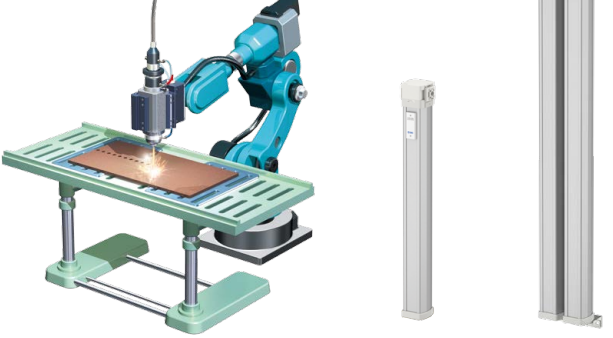

Outlet nitrogen-enriched air flow rate [L/min (ANR)]*1	
Single membrane module 800 type	Double membrane module 1300 + 1300 type
20	56

Vertical pillow packaging machine

For oxidation prevention

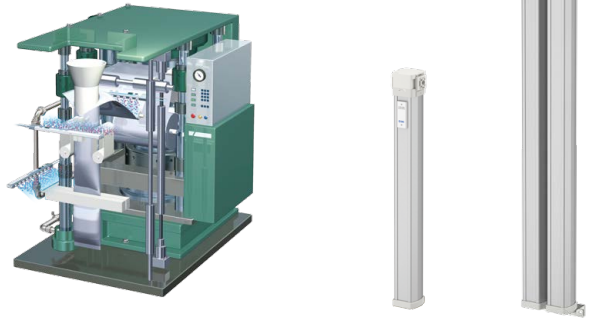

Outlet nitrogen-enriched air flow rate [L/min (ANR)]*1	
Single membrane module 800 type	Double membrane module 1300 + 1300 type
20	56

*1 The outlet nitrogen-enriched air flow rate shown on this page is based on an outlet nitrogen concentration of 99.9%. Be sure to use the product with an outlet nitrogen concentration suitable for each device.
 * For selection, refer to the outlet nitrogen-enriched air flow rate and the outlet nitrogen concentration on pages 13 and 14.

Related Products

Compressed Air Preparation Filter (Modular Connection Type)*1

Compressed Air Purity Class **ISO 8573**

Line Filter
AFF20/30/40-D



1 μm
Filtration efficiency
99 %
Water droplet
removal

Mist Separator
AM20/30/40-D



0.1 μm
Filtration efficiency
99 %
Oil mist
separation
and removal

Micro Mist Separator
AMD20/30/40-D



0.01 μm
Filtration efficiency
99.9 %
Oil mist
separation
and removal

Micro Mist Separator with
Pre-filter
AMH30/40-D



0.01 μm
Filtration efficiency
99.99 %
Oil mist
separation
and removal

Activated Carbon Filter
AMK20/30/40-D



Oil concentration
0.003
mg/m³
Oil vapor
and
odor removal

Bacteria Removal Filter
HF2B-SFDA



Regulator (Modular Connection Type)*1
AR20/30/40-D



Membrane Air Dryer
(Modular Connection Type)*1
IDG20/30/40-D



Digital Flow Switch
PF2M7



Throttle Valve with One-touch Fittings
HF2B-ASG-□TV



*1 NMG50A: Modular connection with size 30 is possible
NMG50B: Modular connection with size 40 is possible
For other sizes, modular connection is possible with a reducing adapter (page 27).

Multi-channel Digital Sensor Monitor
PSE200A

The differential pressure of 2 filters can be managed by a single unit.



Scan or click here for details.

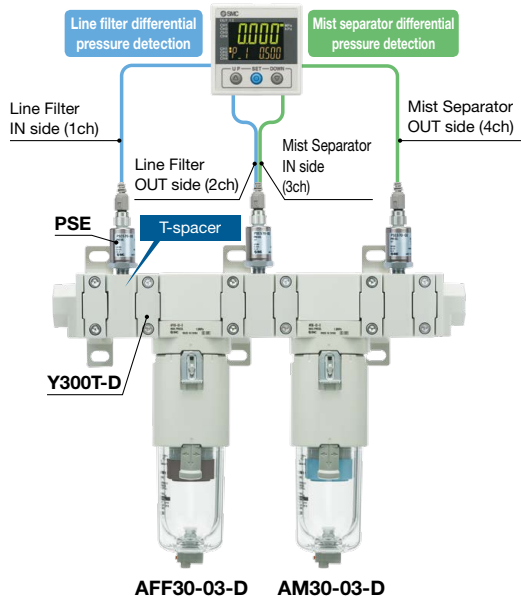

Grease-free Nitrogen (N₂) Compatible Equipment

- To accommodate a wide variety of applications using nitrogen (N₂) gas
- Air preparation filters, Pressure control equipment, Pressure gauges, Fittings, Tubing, Restrictors, Pressure switches, Flow switches, 2/3-port solenoid valves for fluid control, Chemical liquid valves, High vacuum valves, Process gas equipment, Sintered metal elements

Equipment for the Food Manufacturing Industry

Lineup of equipment for various food production processes
By choosing our products, you can contribute to hygiene control, productivity improvement, and energy saving measures that are essential for the food production industry.

CONTENTS

Membrane Nitrogen Generator *NMG Series*



How to Order	p. 7 to 9
Specifications	p. 7 to 9
Performance Graph	p. 10
Characteristics Table	p. 13
Flow Rate Characteristics	p. 15
Dimensions	p. 17
Temperature Correction Method	p. 20
Modular Connection Examples	p. 21
Sold Separately	p. 23
Specific Product Precautions	p. 29

Membrane Nitrogen Generator Single Membrane Module **NMG Series**

RoHS

How to Order

Symbol



NMG50A - **04** N1 - H00 **B** - **□**

①
②
③



NMG50A-04N1
400 type

NMG50A-08N1
800 type

NMG50A-13N1
1300 type

	Symbol	Description	①			
			Module size			
			04	08	13	
② Option	Bottom bracket	Nil	Without bottom bracket	●	●	—
		B	With bottom bracket	●	●	●
+						
③ Semi-standard	Flow direction	Nil	Flow direction: Left to right	●	●	●
		R	Flow direction: Right to left	●	●	●

* The bottom bracket is shipped together with the product.

Specifications

Model		NMG50A-04N1	NMG50A-08N1	NMG50A-13N1
Operating condition range	Fluid	Air		
	Inlet compressed air purity class*1	ISO 8573-1:2010 [1 : 6 : 1]		
	Ambient and fluid temperatures	-5 to 60°C (No freezing or condensation)		
	Proof pressure	1.5 MPa		
	Max. operating pressure	1.0 MPa		
	Min. operating pressure	0.3 MPa		
Rated conditions	Inlet pressure	0.7 MPa		
	Inlet fluid temperature	25°C		
	Ambient temperature	25°C		
	Outlet nitrogen concentration*2	99.9% or more		
	Outlet nitrogen-enriched air flow rate	6.0 L/min (ANR)	20 L/min (ANR)	36 L/min (ANR)
Weight	3.2 kg	6.4 kg	10.7 kg	
	Outlet compressed air purity class*1	ISO 8573-1: 2010 [1 : 3 : 1]	ISO 8573-1: 2010 [1 : 2 : 1]	

*1 The compressed air purity class is indicated based on ISO 8573-1:2010 Compressed air-Part 1: Contaminants and Purity classes.

*2 The nitrogen concentration refers to the total concentration within the compressed air, which contains argon, CO₂, water vapor, and other components in addition to nitrogen and oxygen.

Membrane Nitrogen Generator

Double Membrane Module

NMG Series

RoHS

How to Order

Symbol

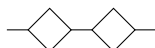

NMG50A-1308-H00B-□

NMG50A-13N2-H00B-□

Flow direction ●

Symbol	Description
Nil	Flow direction: Left to right
R	Flow direction: Right to left

* The bottom bracket is shipped together with the product.

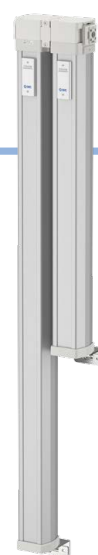

NMG50A-1308
1300 + 800 type

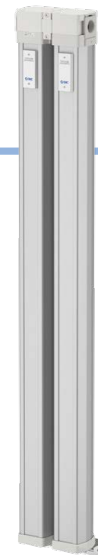

NMG50A-13N2
1300 + 1300 type

Bottom bracket

Specifications

Model		NMG50A-1308	NMG50A-13N2
Operating condition range	Fluid	Air	
	Inlet compressed air purity class* ¹	ISO 8573-1:2010 [1 : 6 : 1]	
	Ambient and fluid temperatures	-5 to 60°C (No freezing or condensation)	
	Proof pressure	1.5 MPa	
	Max. operating pressure	1.0 MPa	
	Min. operating pressure	0.3 MPa	
Rated conditions	Inlet pressure	0.7 MPa	
	Inlet fluid temperature	25°C	
	Ambient temperature	25°C	
	Outlet nitrogen concentration* ²	99.9% or more	
	Outlet nitrogen-enriched air flow rate	44 L/min (ANR)	56 L/min (ANR)
Weight	17.5 kg	21.5 kg	
		ISO 8573-1: 2010 [1 : 2 : 1]	

*¹ The compressed air purity class is indicated based on ISO 8573-1:2010 Compressed air-Part 1: Contaminants and Purity classes.

*² The nitrogen concentration refers to the total concentration within the compressed air, which contains argon, CO₂, water vapor, and other components in addition to nitrogen and oxygen.

Membrane Nitrogen Generator Manifold

NMG Series

RoHS

Top
bracket

How to Order

Symbol

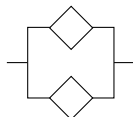

NMG50B-08N2-H00B-

NMG50B-13N2-H00B-

NMG50B-13N3-H00B-

Flow direction ●

Symbol	Description
Nil	Flow direction: Left to right
R	Flow direction: Right to left

* The top and bottom brackets are shipped together with the product.

NMG50B-08N2
800 type x 2

NMG50B-13N2
1300 type x 2

NMG50B-13N3
1300 type x 3

Bottom
bracket

Specifications

Model		NMG50B-08N2	NMG50B-13N2	NMG50B-13N3
Operating condition range	Fluid	Air		
	Inlet compressed air purity class*1	ISO 8573-1:2010 [1 : 6 : 1]		
	Ambient and fluid temperatures	-5 to 60°C (No freezing or condensation)		
	Proof pressure	1.5 MPa		
	Max. operating pressure	1.0 MPa		
	Min. operating pressure	0.3 MPa		
Rated conditions	Inlet pressure	0.7 MPa		
	Inlet fluid temperature	25°C		
	Ambient temperature	25°C		
	Outlet nitrogen concentration*2	99.9% or more		
	Outlet nitrogen-enriched air flow rate	40 L/min (ANR)	72 L/min (ANR)	108 L/min (ANR)
Weight	16.3 kg	24.2 kg	35.4 kg	

*1 The compressed air purity class is indicated based on ISO 8573-1:2010 Compressed air-Part 1: Contaminants and Purity classes.

*2 The nitrogen concentration refers to the total concentration within the compressed air, which contains argon, CO₂, water vapor, and other components in addition to nitrogen and oxygen.

Performance Graph (Temperature 25°C): Single Membrane Module

NMG50A-04N1

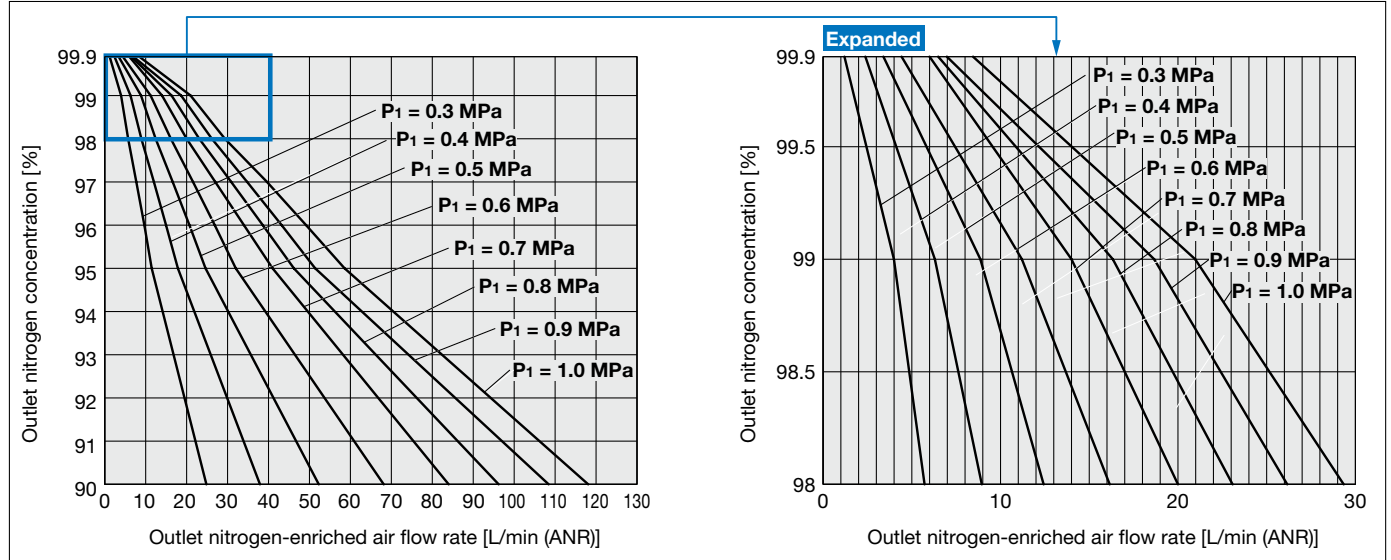

NMG50A-08N1

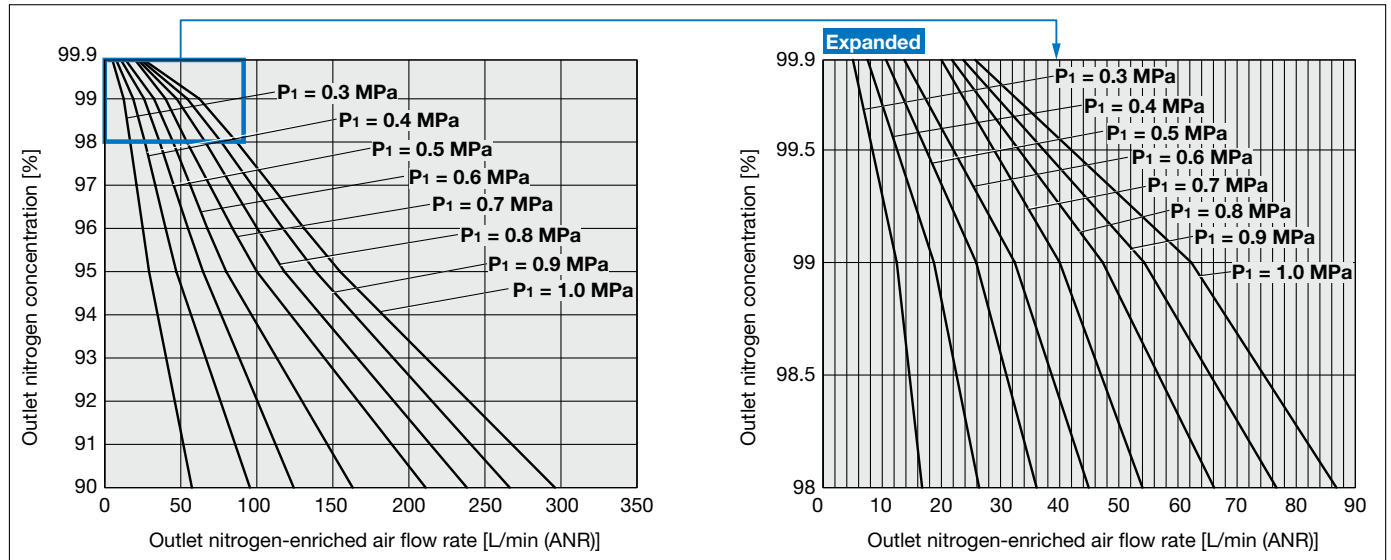

NMG50A-13N1

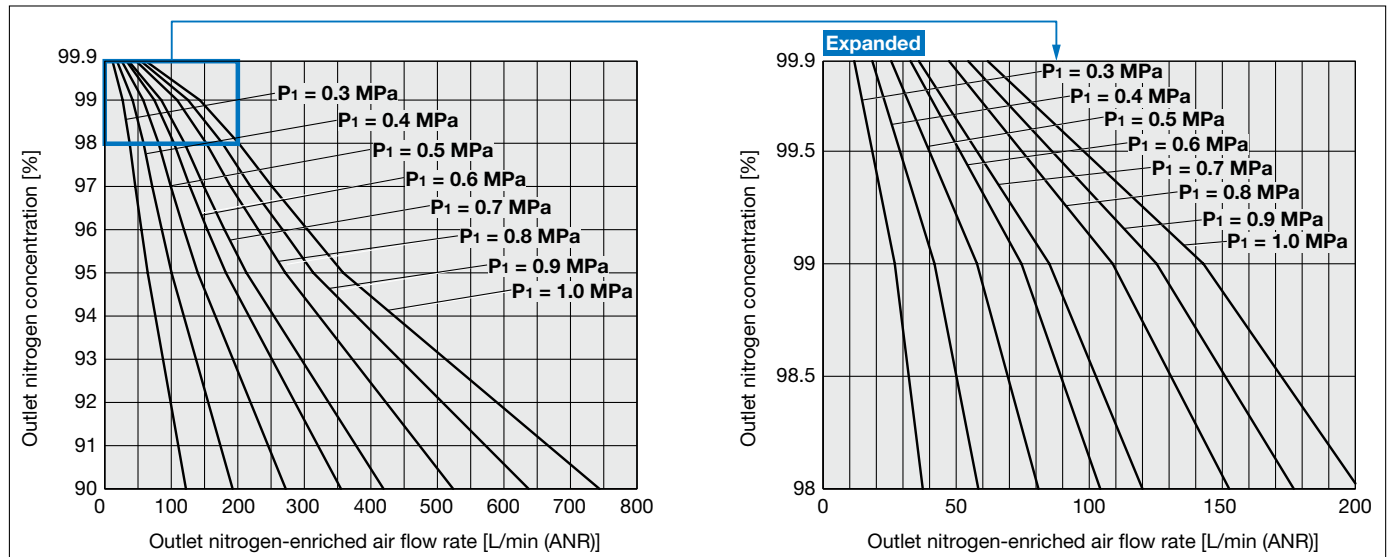

Performance Graph (Temperature 25°C): Double Membrane Module

NMG50A-1308

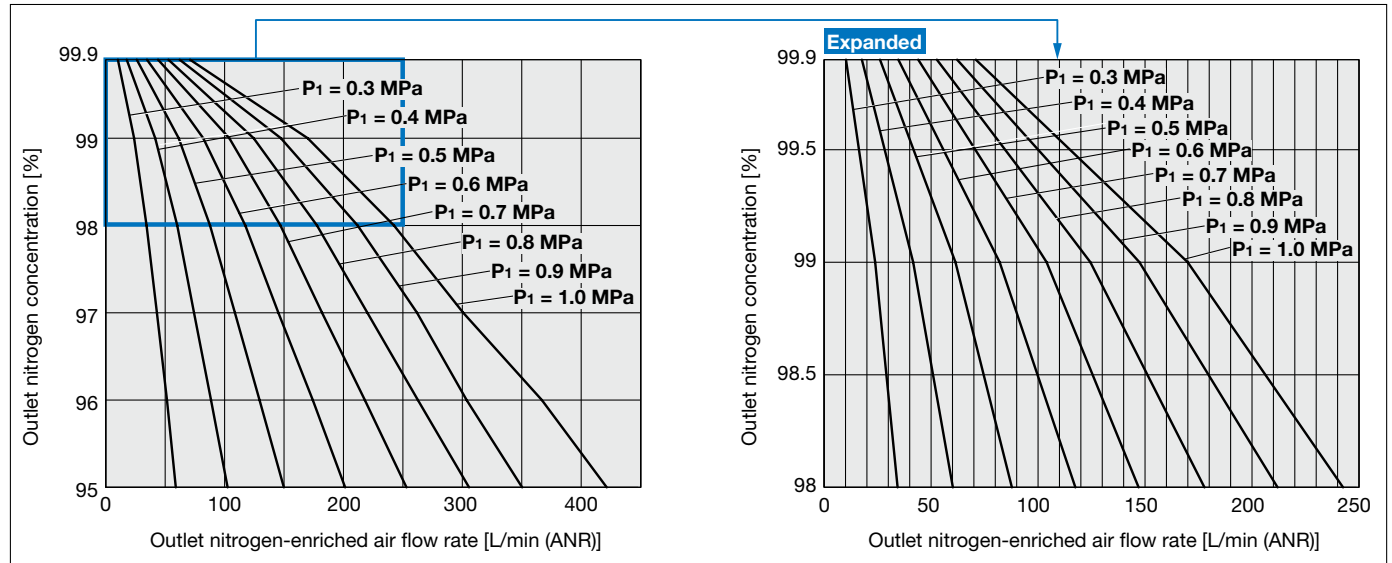

NMG50A-13N2

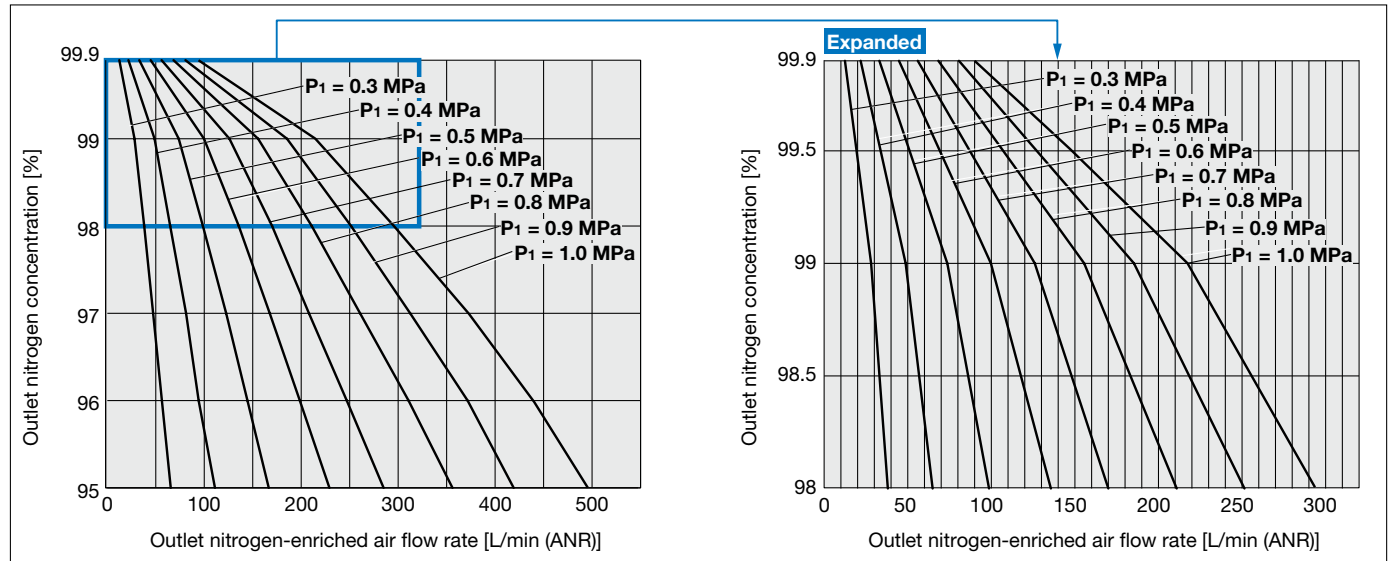

Performance Graph (Temperature 25°C): Manifold

NMG50B-08N2

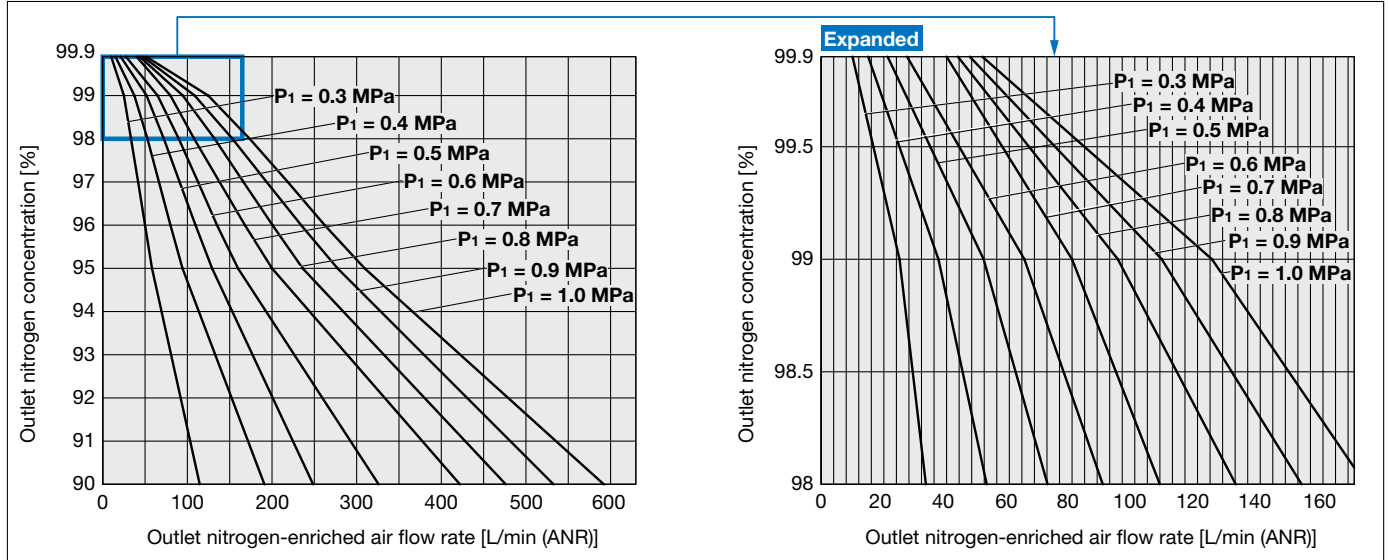

NMG50B-13N2

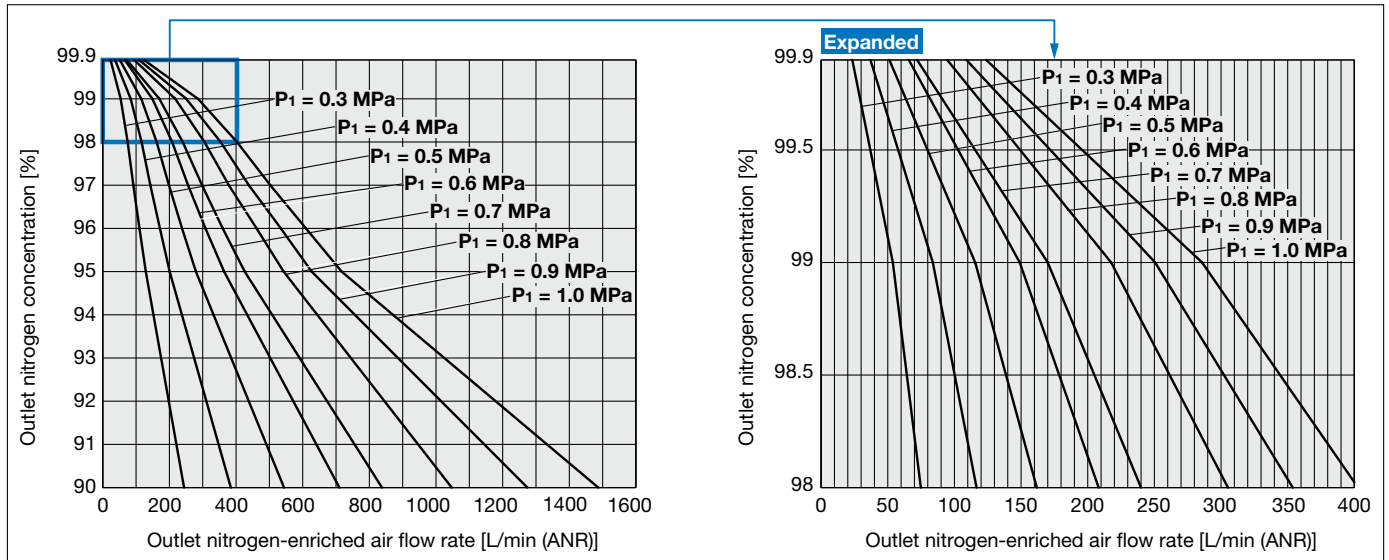

NMG50B-13N3

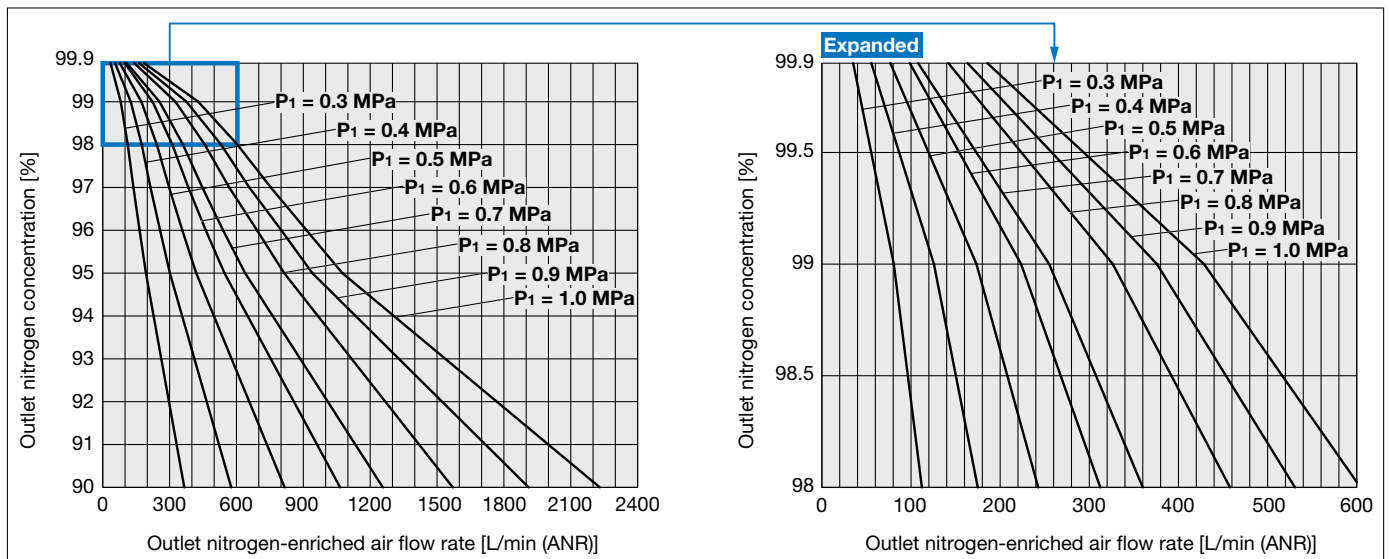

Characteristics Table (Inlet air conditions: Temperature 25°C)

Single Membrane Module

NMG50A-04N1

Outlet Nitrogen-enriched Air Flow Rate [L/min (ANR)]

Outlet nitrogen concentration [%]	Outlet nitrogen-enriched air flow rate (inlet pressure)								
	0.3 MPa	0.4 MPa	0.5 MPa	0.6 MPa	0.7 MPa	0.8 MPa	0.9 MPa	1.0 MPa	
99.9	1.2	2.4	3.4	4.4	6.0	6.5	7.0	8.5	
99	4.0	6.3	8.9	11.2	14.0	16.3	18.7	21.0	
98	5.7	8.9	12.4	16.2	20.0	23.1	26.2	29.3	
97	8.3	12.9	17.8	23.2	29.0	33.2	37.4	42.6	
96	10.0	15.4	21.3	27.7	35.0	39.7	44.5	50.6	
95	11.5	17.9	24.6	32.0	41.0	46.2	51.4	58.6	
90	24.8	37.9	52.3	68.1	84.0	96.2	108.4	118.1	

Inlet Air Flow Rate (Reference values) [L/min (ANR)]

Outlet nitrogen concentration [%]	Inlet flow rate (inlet pressure)								
	0.3 MPa	0.4 MPa	0.5 MPa	0.6 MPa	0.7 MPa	0.8 MPa	0.9 MPa	1.0 MPa	
99.9	14	21	29	36	43	50	57	64	
99	18	27	36	45	53	63	71	80	
98	20	30	40	50	60	71	80	91	
97	23	35	47	58	70	82	93	105	
96	26	39	51	64	77	90	103	116	
95	28	42	56	70	84	98	111	126	
90	42	64	85	106	127	149	169	191	

NMG50A-08N1

Outlet Nitrogen-enriched Air Flow Rate [L/min (ANR)]

Outlet nitrogen concentration [%]	Outlet nitrogen-enriched air flow rate (inlet pressure)								
	0.3 MPa	0.4 MPa	0.5 MPa	0.6 MPa	0.7 MPa	0.8 MPa	0.9 MPa	1.0 MPa	
99.9	5.0	7.5	10.6	13.7	20.0	21.8	23.7	25.7	
99	12.5	18.7	25.9	32.4	40.0	47.3	54.3	62.3	
98	16.7	26.4	36.1	44.9	54.0	66.1	76.6	86.8	
97	20.9	33.2	45.4	56.3	69.0	83.1	96.8	109.3	
96	25.0	40.0	54.8	67.5	84.0	100.3	117.2	131.1	
95	29.1	47.1	64.6	79.9	100.0	118.1	138.7	154.7	
90	57.3	95.5	124.3	163.0	211.0	238.1	266.3	296.0	

Inlet Air Flow Rate (Reference values) [L/min (ANR)]

Outlet nitrogen concentration [%]	Inlet flow rate (inlet pressure)								
	0.3 MPa	0.4 MPa	0.5 MPa	0.6 MPa	0.7 MPa	0.8 MPa	0.9 MPa	1.0 MPa	
99.9	48	71	95	119	143	167	190	214	
99	57	85	113	142	170	199	226	255	
98	63	94	125	156	188	220	250	282	
97	68	103	137	171	205	240	273	308	
96	74	111	148	185	222	260	295	333	
95	80	120	160	200	240	281	319	360	
90	117	176	234	293	351	411	467	527	

NMG50A-13N1

Outlet Nitrogen-enriched Air Flow Rate [L/min (ANR)]

Outlet nitrogen concentration [%]	Outlet nitrogen-enriched air flow rate (inlet pressure)								
	0.3 MPa	0.4 MPa	0.5 MPa	0.6 MPa	0.7 MPa	0.8 MPa	0.9 MPa	1.0 MPa	
99.9	11.7	18.5	25.6	32.9	36.0	47.3	54.5	61.9	
99	26.9	41.9	57.8	74.5	85.0	108.8	125.3	142.9	
98	37.4	58.3	80.9	104.1	120.0	152.6	176.9	201.4	
97	45.9	71.4	99.3	128.0	149.0	189.2	219.2	251.4	
96	55.1	85.8	119.0	154.1	180.0	230.8	267.2	304.9	
95	64.6	100.4	139.8	182.1	213.0	271.4	313.5	358.4	
90	122.0	192.2	272.0	355.1	419.0	523.6	637.1	743.5	

Inlet Air Flow Rate (Reference values) [L/min (ANR)]

Outlet nitrogen concentration [%]	Inlet flow rate (inlet pressure)								
	0.3 MPa	0.4 MPa	0.5 MPa	0.6 MPa	0.7 MPa	0.8 MPa	0.9 MPa	1.0 MPa	
99.9	86	129	171	214	257	300	343	386	
99	99	148	198	247	296	346	395	445	
98	118	177	236	295	354	413	472	531	
97	122	183	245	306	367	428	489	550	
96	133	200	267	334	400	467	534	601	
95	145	217	290	362	435	507	580	652	
90	214	320	427	534	641	747	854	961	

Double Membrane Module

NMG50A-1308

Outlet Nitrogen-enriched Air Flow Rate [L/min (ANR)]

Outlet nitrogen concentration [%]	Outlet nitrogen-enriched air flow rate (inlet pressure)								
	0.3 MPa	0.4 MPa	0.5 MPa	0.6 MPa	0.7 MPa	0.8 MPa	0.9 MPa	1.0 MPa	
99.9	10.2	17.7	26.1	34.7	44.0	52.7	62.2	70.9	
99	23.9	41.6	61.4	82.1	104.0	124.5	147.4	169.9	
98	34.3	60.2	87.8	117.4	147.0	177.8	211.9	242.5	
97	43.1	74.3	108.7	145.3	182.0	220.1	261.9	300.8	
96	51.5	88.6	129.4	174.2	218.0	262.6	303.6	366.9	
95	58.9	102.5	149.9	201.4	253.0	305.7	350.3	421.5	

Inlet Air Flow Rate (Reference values) [L/min (ANR)]

Outlet nitrogen concentration [%]	Inlet flow rate (inlet pressure)								
	0.3 MPa	0.4 MPa	0.5 MPa	0.6 MPa	0.7 MPa	0.8 MPa	0.9 MPa	1.0 MPa	
99.9	104	156	208	260	312	365	415	468	
99	127	190	254	317	381	445	506	571	
98	142	213	284	356	427	499	567	640	
97	154	232	309	386	463	542	616	695	
96	167	250	334	417	501	586	666	751	
95	179	268	358	447	537	628	714	805	

NMG50A-13N2

Outlet Nitrogen-enriched Air Flow Rate [L/min (ANR)]

Outlet nitrogen concentration [%]	Outlet nitrogen-enriched air flow rate (inlet pressure)								
	0.3 MPa	0.4 MPa	0.5 MPa	0.6 MPa	0.7 MPa	0.8 MPa	0.9 MPa	1.0 MPa	
99.9	12.4	21.8	33.0	44.8	56.0	68.3	80.6	94.5	
99	28.1	48.7	73.7	99.7	126.0	155.6	185.4	216.0	
98	38.1	64.9	98.6	135.6	170.0	210.9	251.4	295.1	
97	47.3	81.3	122.6	167.6	208.0	260.7	312.4	366.1	
96	56.3	94.2	144.6	198.6	247.0	310.7	371.7	429.8	
95	65.4	111.0	166.5	229.1	285.0	356.0	419.2	491.1	

Inlet Air Flow Rate (Reference values) [L/min (ANR)]

Outlet nitrogen concentration [%]	Inlet flow rate (inlet pressure)								
	0.3 MPa	0.4 MPa	0.5 MPa	0.6 MPa	0.7 MPa	0.8 MPa	0.9 MPa	1.0 MPa	
99.9	133	200	267	333	400	468	532	600	
99	158	237	315	394	473	554	629	710	
98	172	258	344	430	516	603	686	774	
97	184	275	367	459	551	644	732	826	
96	195	292	390	487	585	684	778	877	
95	206	309	412	515	618	723	822	927	

Characteristics Table (Inlet air conditions: Temperature 25°C)

Manifold

NMG50B-08N2

Outlet Nitrogen-enriched Air Flow Rate [L/min (ANR)]

Outlet nitrogen concentration [%]	Outlet nitrogen-enriched air flow rate (inlet pressure)							
	0.3 MPa	0.4 MPa	0.5 MPa	0.6 MPa	0.7 MPa	0.8 MPa	0.9 MPa	1.0 MPa
99.9	10.0	15.0	21.2	27.4	40.0	43.6	47.4	51.4
99	25.0	37.4	51.8	64.8	80.0	94.6	108.6	124.6
98	33.4	52.8	72.2	89.8	108.0	132.2	153.2	173.6
97	41.8	66.4	90.8	112.6	138.0	166.2	193.6	218.6
96	50.0	80.0	109.6	135.0	168.0	200.6	234.4	262.2
95	58.2	94.2	129.2	159.8	200.0	236.2	277.4	309.4
90	114.6	191.0	248.6	326.0	422.0	476.2	532.6	592.0

Inlet Air Flow Rate (Reference values) [L/min (ANR)]

Outlet nitrogen concentration [%]	Inlet flow rate (inlet pressure)							
	0.3 MPa	0.4 MPa	0.5 MPa	0.6 MPa	0.7 MPa	0.8 MPa	0.9 MPa	1.0 MPa
99.9	96	142	190	238	286	334	380	428
99	114	170	226	284	340	398	452	510
98	126	188	250	312	376	440	500	564
97	136	206	274	342	410	480	546	616
96	148	222	296	370	444	520	590	666
95	160	240	320	400	480	562	638	720
90	234	352	468	586	702	822	934	1054

NMG50B-13N2

Outlet Nitrogen-enriched Air Flow Rate [L/min (ANR)]

Outlet nitrogen concentration [%]	Outlet nitrogen-enriched air flow rate (inlet pressure)							
	0.3 MPa	0.4 MPa	0.5 MPa	0.6 MPa	0.7 MPa	0.8 MPa	0.9 MPa	1.0 MPa
99.9	23.4	37.0	51.2	65.8	72.0	94.6	109.0	123.8
99	53.8	83.8	115.6	149.0	170.0	217.6	250.6	285.8
98	74.8	116.6	161.8	208.2	240.0	305.2	353.8	402.8
97	91.8	142.8	198.6	256.0	298.0	378.4	438.4	502.8
96	110.2	171.6	238.0	308.2	360.0	461.6	534.4	609.8
95	129.2	200.8	279.6	364.2	426.0	542.8	627.0	716.8
90	244.0	384.4	544.0	710.2	838.0	1047.2	1274.2	1487.0

Inlet Air Flow Rate (Reference values) [L/min (ANR)]

Outlet nitrogen concentration [%]	Inlet flow rate (inlet pressure)							
	0.3 MPa	0.4 MPa	0.5 MPa	0.6 MPa	0.7 MPa	0.8 MPa	0.9 MPa	1.0 MPa
99.9	172	258	342	428	514	600	686	772
99	198	296	396	494	592	692	790	890
98	236	354	472	590	708	826	944	1062
97	244	366	490	612	734	856	978	1100
96	266	400	534	668	800	934	1068	1202
95	290	434	580	724	870	1014	1160	1304
90	428	640	854	1068	1282	1494	1708	1922

NMG50B-13N3

Outlet Nitrogen-enriched Air Flow Rate [L/min (ANR)]

Outlet nitrogen concentration [%]	Outlet nitrogen-enriched air flow rate (inlet pressure)							
	0.3 MPa	0.4 MPa	0.5 MPa	0.6 MPa	0.7 MPa	0.8 MPa	0.9 MPa	1.0 MPa
99.9	35.1	55.5	76.8	98.7	108.0	141.9	163.5	185.7
99	80.7	125.7	173.4	223.5	255.0	326.4	375.9	428.7
98	112.2	174.9	242.7	312.3	360.0	457.8	530.7	604.2
97	137.7	214.2	297.9	384.0	447.0	567.6	657.6	754.2
96	165.3	257.4	357.0	462.3	540.0	692.4	801.6	914.7
95	193.8	301.2	419.4	546.3	639.0	814.2	940.5	1075.2
90	366.0	576.6	816.0	1065.3	1257.0	1570.8	1911.3	2230.5

Inlet Air Flow Rate (Reference values) [L/min (ANR)]

Outlet nitrogen concentration [%]	Inlet flow rate (inlet pressure)							
	0.3 MPa	0.4 MPa	0.5 MPa	0.6 MPa	0.7 MPa	0.8 MPa	0.9 MPa	1.0 MPa
99.9	258	387	513	642	771	900	1029	1158
99	297	444	594	741	888	1038	1185	1335
98	354	531	708	885	1062	1239	1416	1593
97	366	549	735	918	1101	1284	1467	1650
96	399	600	801	1002	1200	1401	1602	1803
95	435	651	870	1086	1305	1521	1740	1956
90	642	960	1281	1602	1923	2241	2562	2883

NMG Series

Flow Rate Characteristics (Representative values)

Single Membrane Module

NMG50A-04N1

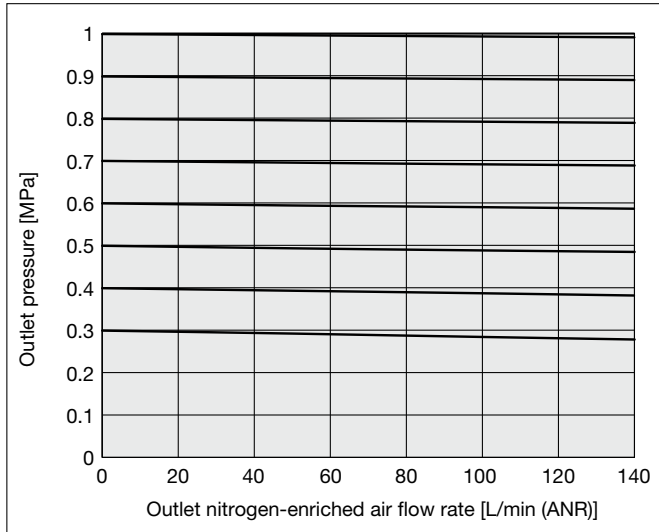

NMG50A-08N1

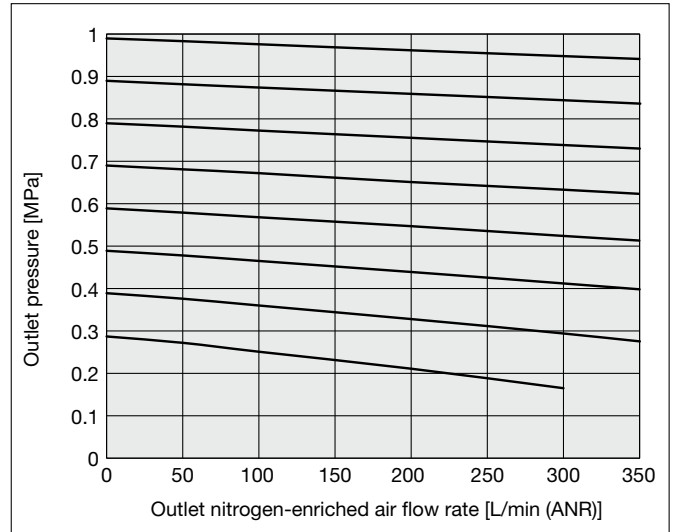

NMG50A-13N1

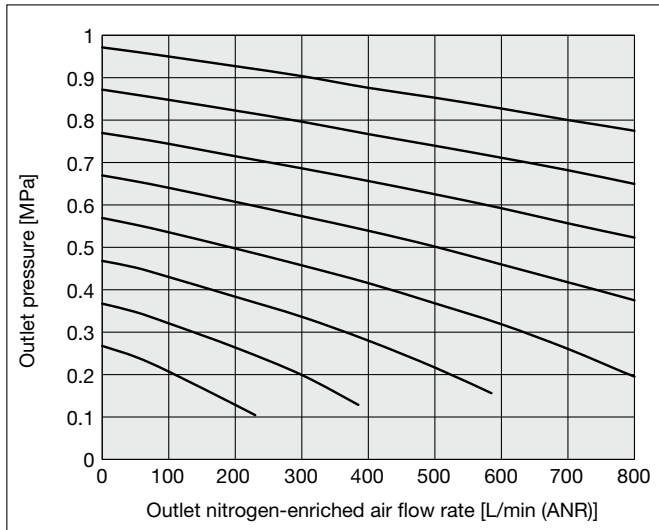

Double Membrane Module

NMG50A-1308

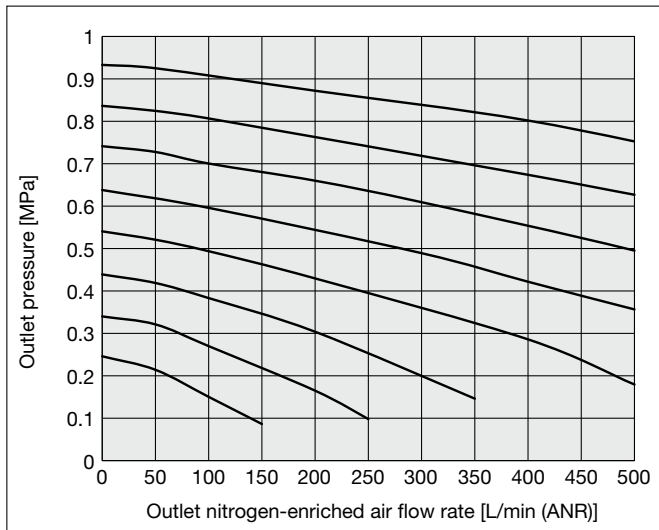

NMG50A-13N2

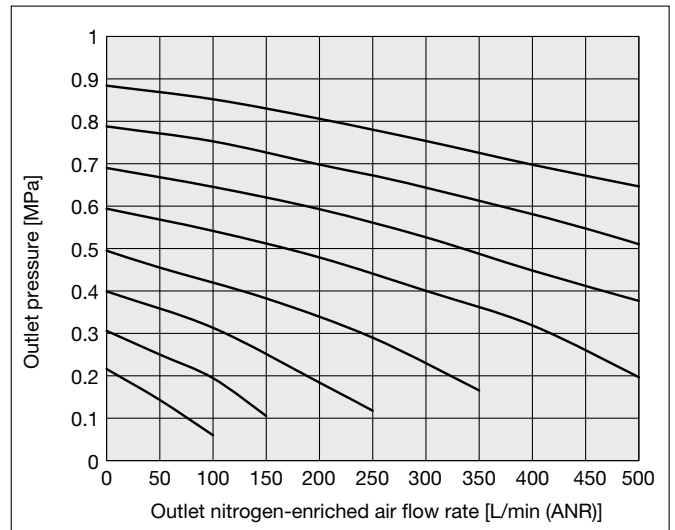

Flow Rate Characteristics (Representative values)

Manifold

NMG50B-08N2

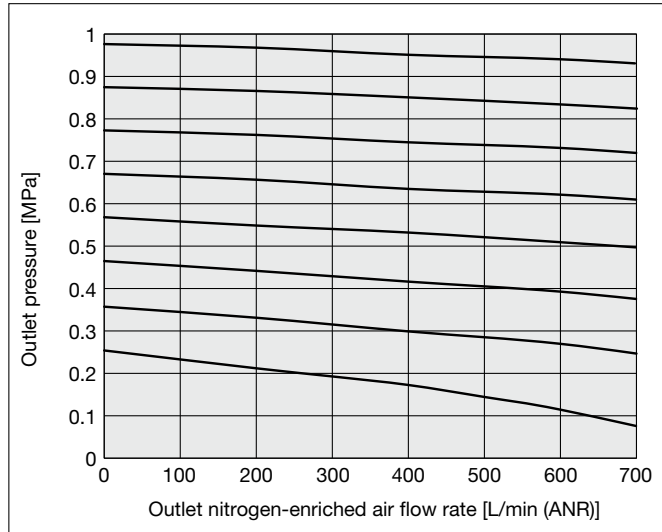

NMG50B-13N2

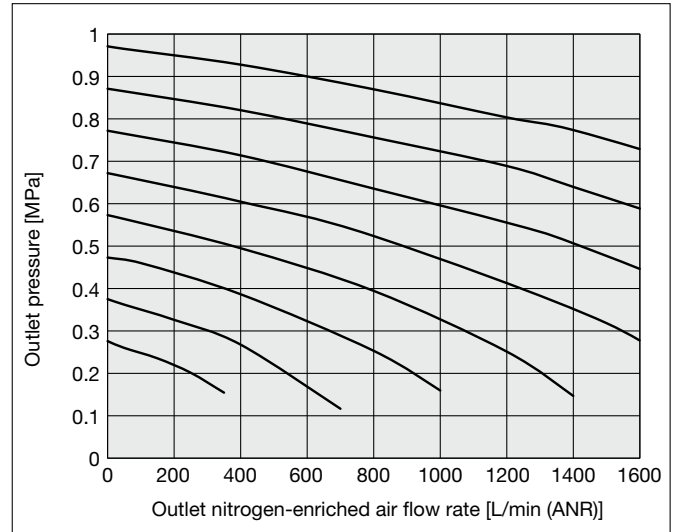

NMG50B-13N3

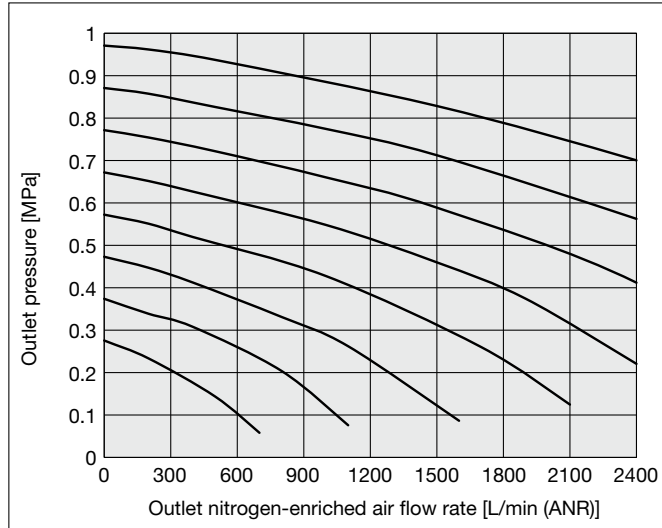

NMG Series

Dimensions: Single Membrane Module

NMG50A-04N1
 NMG50A-08N1
 NMG50A-13N1

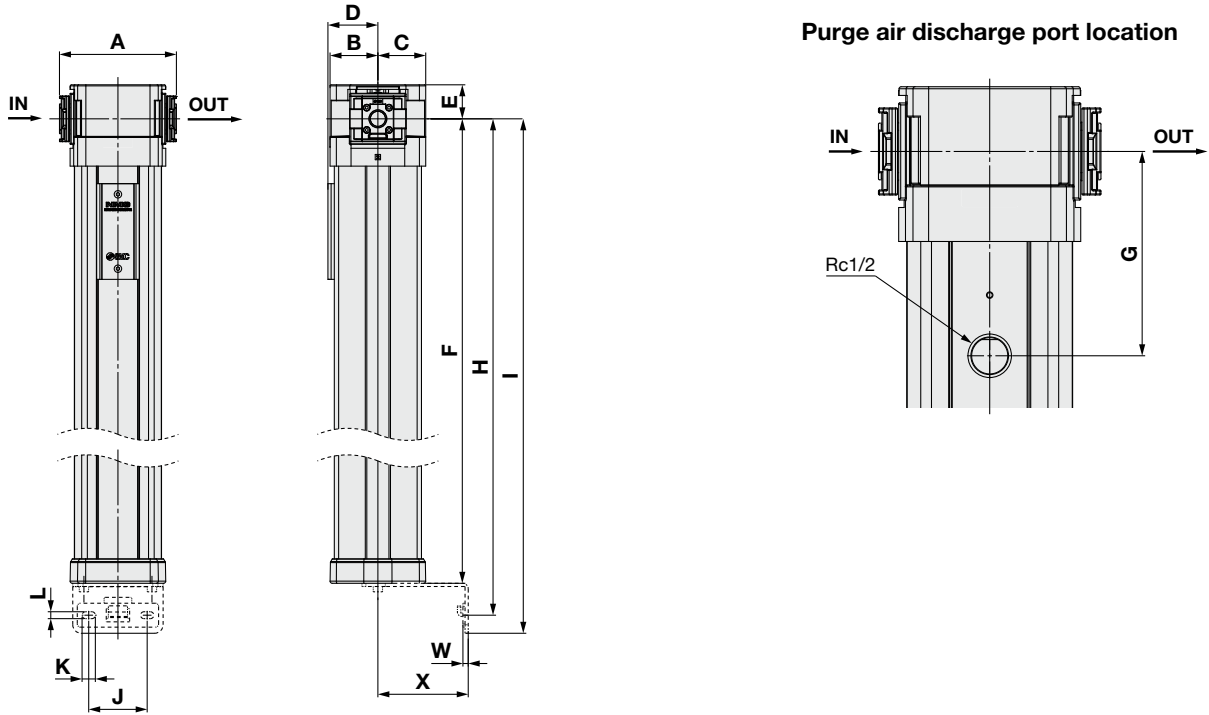

Model	Standard specifications													Applicable AC size	Applicable spacer/ spacer with bracket	
	A	B	C	D	E	F	G	Bottom bracket mount								
								H	I	J	K	L	W	X		
NMG50A-04N1						357	101	387	404							
NMG50A-08N1	110	45	45	47	32	782	101	812	829	55	12.5	6.5	5	85	AC30-D	Y300-D/Y300T-2-D
NMG50A-13N1						1293	89/123	1323	1340							

* Pipe threads are not provided on the face which connects with the other components. For use, a separate spacer with bracket (or spacer) is required. Refer to AC-D series attachments/piping adapters for selection.

Dimensions: Double Membrane Module

NMG50A-13N2

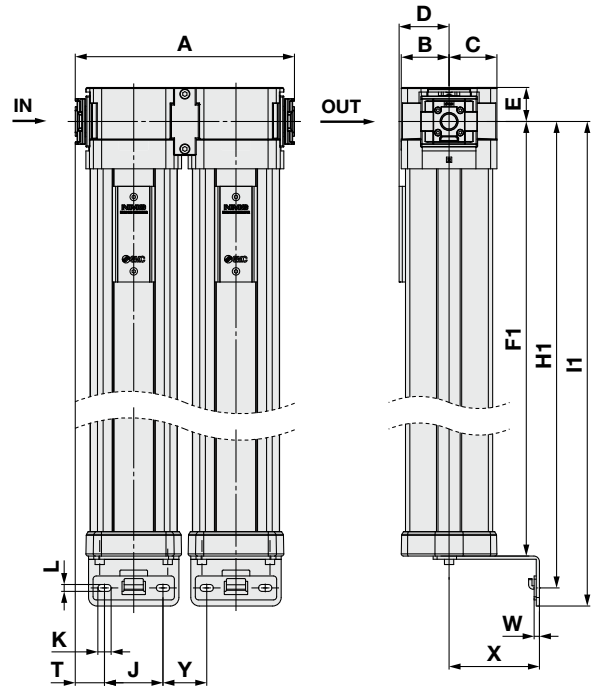

NMG50A-1308

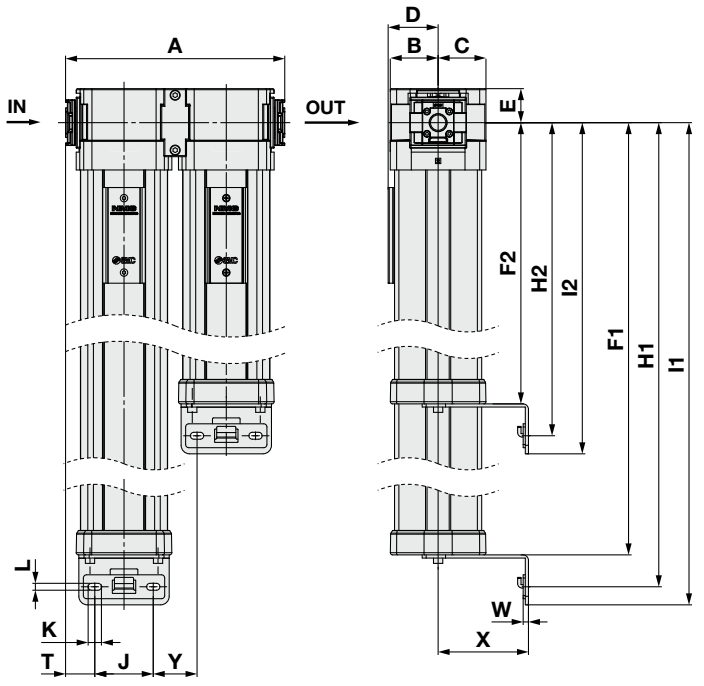

Model	Standard specifications																	Applicable AC size	Applicable spacer/ spacer with bracket		
	A	B	C	D	E	F1	F2	H1	H2	I1	I2	J	K	L	T	W	X			Y	
NMG50A-13N2	206.2	45	45	47	32	1293	—	1323	—	1340	—	55	12.5	6.5	27.5	5	85	41.2	AC30-D	Y300-D/Y300T-2-D	
NMG50A-1308							782		812		829										

* Pipe threads are not provided on the face which connects with the other components. For use, a separate spacer with bracket (or spacer) is required. Refer to AC-D series attachments/piping adapters for selection.

NMG Series

Dimensions: Manifold

NMG50B-08N2
 NMG50B-13N2
 NMG50B-13N3

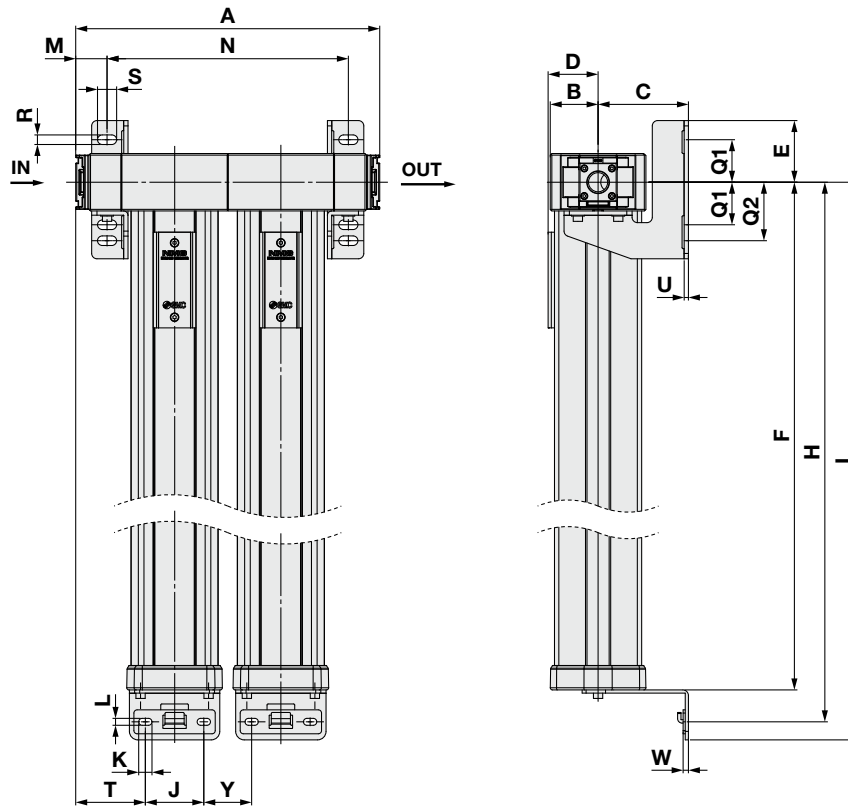

Model	Standard specifications																			Applicable AC size	Applicable spacer/ spacer with bracket			
	Top bracket mount											Bottom bracket mount												
	A	B	D	F	C	E	M	N	Q1	Q2	R	S	U	H	I	J	K	L	T	W	Y			
NMG50B-08N2				768										798	815									
NMG50B-13N2	286	45	47	1279	85	58	29.5	227	40	55	9	18	4	1309	1326	55	12.5	6.5	65.5	5	45	AC40-D	Y400-D/Y400T-1-D	
NMG50B-13N3	386				327																			

* Pipe threads are not provided on the face which connects with the other components. For use, a separate spacer with bracket (or spacer) is required. Refer to AC-D series attachments/piping adapters for selection.

Temperature Correction Method

The nitrogen enrichment performance of this product (outlet nitrogen concentration and outlet nitrogen-enriched air flow rate) varies depending on the inlet air temperature. When using it under different temperature conditions, refer to the corrected outlet nitrogen-enriched air flow rate (hereafter, corrected outlet air flow rate) obtained by following the procedure below.

Procedure

- ① Read the outlet nitrogen-enriched air flow rate Q under the operating conditions from the characteristic table (at 25°C).
- ② Read the temperature correction factor from the temperature correction factor table, based on the inlet temperature and outlet nitrogen concentration.
- ③ Corrected outlet air flow rate $Q' = (① Q) \times (② \text{ correction factor})$

Temperature Correction Factor Table

Inlet temperature [°C]	Outlet nitrogen concentration						
	99.9%	99%	98%	97%	96%	95%	90%
15°C	1.03	0.95	0.93	0.92	0.91	0.91	0.90
20°C	1.01	0.95	0.95	0.95	0.94	0.94	0.94
25°C	1.00	1.00	1.00	1.00	1.00	1.00	1.00
30°C	0.98	1.03	1.04	1.05	1.05	1.07	1.15
35°C	0.94	1.06	1.07	1.09	1.10	1.11	1.21
40°C	0.95	1.09	1.12	1.14	1.15	1.17	1.28

[Example of operating conditions]

Model NMG50A-04N1
 Inlet air pressure P₁ 0.7 MPa
 Outlet nitrogen concentration 98%
 Outlet nitrogen-enriched air flow rate Q 20 L/min (ANR)
 Inlet air temperature 20°C

[Calculation example]

- ① Read the outlet nitrogen-enriched air flow rate Q under the operating conditions from the characteristic table (at 25°C).
⇒ 20 L/min (ANR)
- ② Read the temperature correction factor from the temperature correction factor table, based on the inlet temperature and outlet nitrogen concentration.
⇒ 0.95
- ③ Corrected flow rate $Q' = (① Q) \times (② \text{ temperature correction factor})$
⇒ Corrected outlet air flow rate $Q' = 20 \times 0.95 = \mathbf{19 \text{ L/min (ANR)}}$

Assembly Examples

Products do not come assembled. They should be ordered separately and assembled by the customer. Use a spacer with a bracket when connecting modular units. When the inlet air flow rate exceeds 1500 L/min (ANR)*1, air preparation equipment of size AC50 or larger must be selected. Contact SMC for modular connection examples in such cases.
*1 Refer to the inlet air flow rate (reference values) in the Characteristics Table.

**When using an [AFF + AMH + AMK]
Compressed air purity class compliant with ISO 8573-1:2010
Inlet air purity class ISO 8573-1:2010 [1:6:1]**

Assembly Example

- | | |
|--|--------|
| ① Line filter AFF30-□-D | 1 pc. |
| ② Micro mist separator with pre-filter AMH30-□-D | 1 pc. |
| ③ Activated carbon filter AMK30-□-D | 1 pc. |
| ④ Membrane nitrogen generator NMG50A-04N1-H00 | 1 pc. |
| ⑤ Regulator AR30-□E-D | 1 pc. |
| ⑥ Spacer with bracket Y300T-2-D | 4 pcs. |

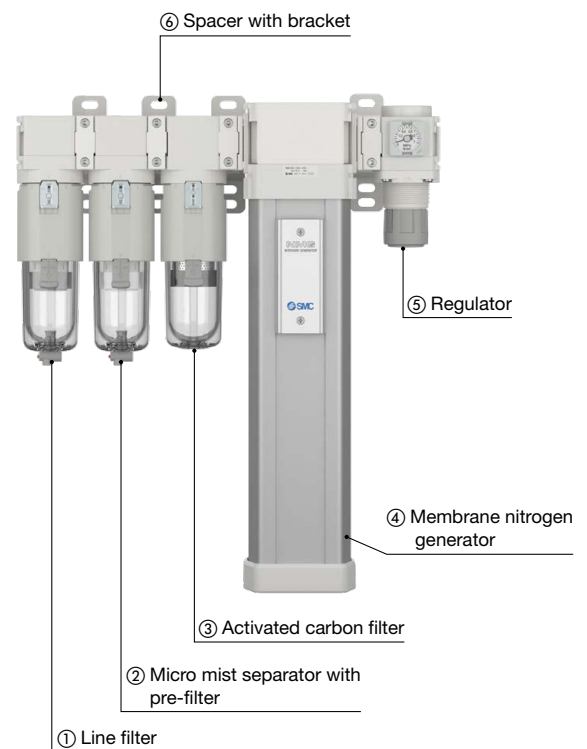

Assembly Example

- | | |
|---|--------|
| ① Piping adapter E300-□-D | 2 pcs. |
| ② Membrane nitrogen generator NMG50A-04N1-H00 | 1 pc. |
| ③ Spacer with bracket Y300T-2-D | 2 pcs. |

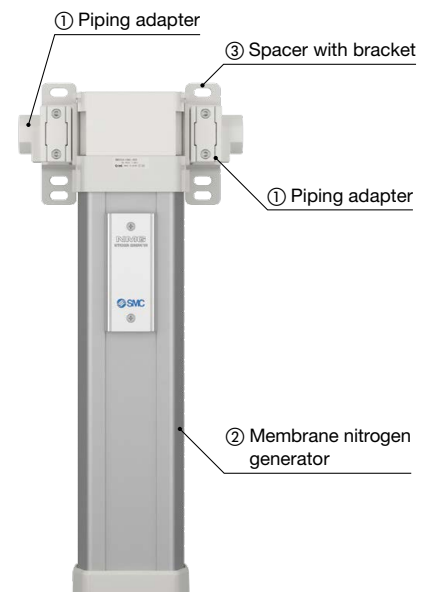

Assembly Example

Assembly Example

- | | |
|--|--------|
| ① Line filter AFF30-D | 1 pc. |
| ② Micro mist separator with pre-filter AMH30-D | 1 pc. |
| ③ Activated carbon filter AMK30-D | 1 pc. |
| ④ Membrane nitrogen generator NMG50B-08N2 | 1 pc. |
| ⑤ Spacer with bracket Y300T-2-D | 3 pcs. |
| ⑥ Spacer Y400-D | 2 pcs. |
| ⑦ Reducing adapter E410R-D | 1 pc. |
| ⑧ Regulator AR40-03E-D | 1 pc. |

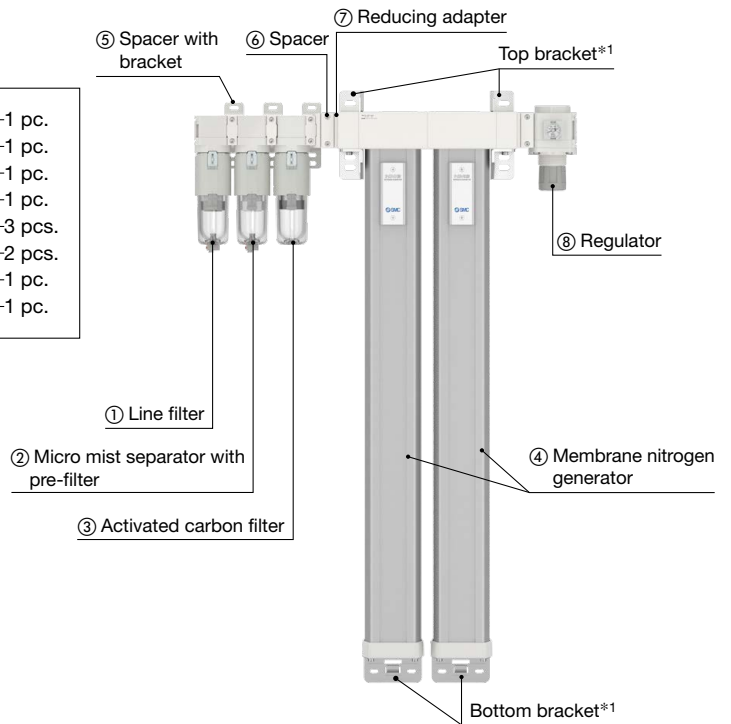

Assembly Example

- | | |
|--|--------|
| ① Line filter AFF40-D | 1 pc. |
| ② Micro mist separator with pre-filter AMH40-D | 1 pc. |
| ③ Activated carbon filter AMK40-D | 1 pc. |
| ④ Membrane nitrogen generator NMG50B-13N3 | 1 pc. |
| ⑤ Spacer with bracket Y400T-1-D | 2 pcs. |
| ⑥ Spacer Y400-D | 2 pcs. |
| ⑦ Regulator AR40-03E-D | 1 pc. |

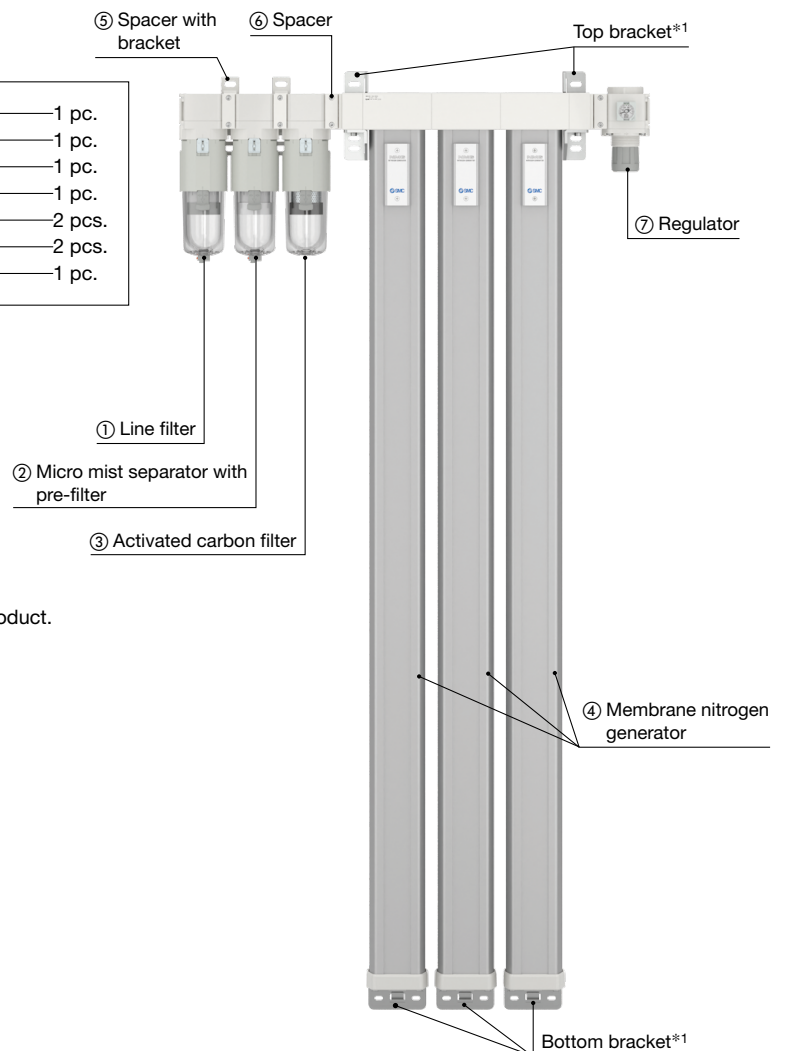

*1 The top and bottom brackets are shipped together with the product.

NMG Series

Sold Separately

Piping Adapter: 1/8, 1/4, 3/8, 1/2, 3/4, 1, 1 1/4, 1 1/2

· Using on the inlet side or the outlet side makes it easier to perform maintenance, as the component can be installed/removed without removing the piping.

E **300** - **03** - **D**

① ② ③

	Symbol	Description	①		
			Body size [Applicable AC size]		
			200 [AC20]	300 [AC30]	400 [AC40]
② Pipe thread type	Nil	Rc	●	●	●
	N	NPT	●	●	●
	F	G	●	●	●
+					
③ Port size	01	1/8	●	—	—
	02	1/4	●	●	●
	03	3/8	●	●	●
	04	1/2	—	●	●
	06	3/4	—	—	●

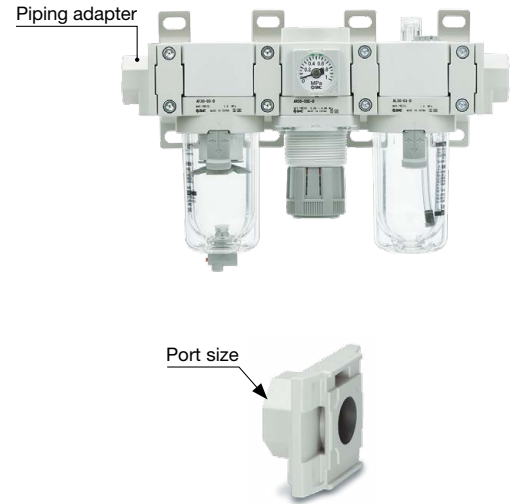

Standard Specifications

Fluid	Air
Ambient and fluid temperatures	-5 to 60°C (No freezing)
Proof pressure	1.5 MPa
Max. operating pressure	1.0 MPa

Dimensions

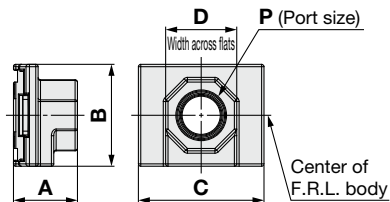

Model	P	A	B	C	D	Applicable AC size
E200-D	1/8, 1/4, 3/8	24	35	42	24	AC20-D
E300-D	1/4, 3/8, 1/2	27	43	53	30	AC30-D
E400-D	1/4, 3/8, 1/2, 3/4	30	51	71	36	AC40-D

Caution on Mounting

Pipe threads are not provided on the face which connects with the other components. For use, a separate spacer (or spacer with bracket) is required.

L-Shaped Piping Adapter: 1/8, 1/4, 3/8, 1/2, 3/4, 1

- Upward/downward piping is possible on the inlet side and the outlet side.
- Ideal for space-saving and reducing piping labor
- Using on the inlet side or the outlet side makes it easier to perform maintenance, as the component can be installed/removed without removing the piping.

E **300** **L** - **□** **03** - **D**

① ② ③

	Symbol	Description	①		
			Body size [Applicable AC size]		
			200 [AC20]	300 [AC30]	400 [AC40]
② Pipe thread type	Nil	Rc	●	●	●
	N	NPT	●	●	●
	F	G	●	●	●
+					
③ Port size	01	1/8	●	●	—
	02	1/4	●	●	●
	03	3/8	—	●	●
	04	1/2	—	—	●



Standard Specifications

Fluid	Air
Ambient and fluid temperatures	-5 to 60°C (No freezing)
Proof pressure	1.5 MPa
Max. operating pressure	1.0 MPa

Dimensions

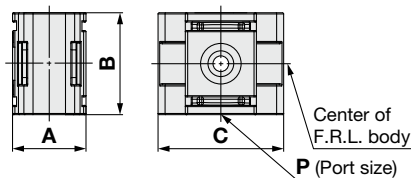

Model	P	A	B	C	Applicable AC size
E200L-D	1/8, 1/4	28	35	42	AC20-D
E300L-D	1/8, 1/4, 3/8	31	43	53	AC30-D
E400L-D	1/4, 3/8, 1/2	39	51	71	AC40-D

Caution on Mounting

Pipe threads are not provided on the face which connects with the other components. For use, a separate spacer (or spacer with bracket) is required.

NMG Series

T-Shaped Piping Adapter: 1/8, 1/4, 3/8, 1/2, 3/4, 1

- Both upward and downward piping are possible on the inlet and outlet sides.
- Ideal for space-saving and reducing piping labor
- Using on the inlet side or the outlet side makes it easier to perform maintenance, as the component can be installed/removed without removing the piping.

E **300** **T** - **03** - **D**

① ② ③

	Symbol	Description	①		
			Body size [Applicable AC size]		
			200 [AC20]	300 [AC30]	400 [AC40]
② Pipe thread type	Nil	Rc	●	●	●
	N	NPT	●	●	●
	F	G	●	●	●
+					
③ Port size	01	1/8	●	●	—
	02	1/4	●	●	●
	03	3/8	—	●	●
	04	1/2	—	—	●

Standard Specifications

Fluid	Air
Ambient and fluid temperatures	-5 to 60°C (No freezing)
Proof pressure	1.5 MPa
Max. operating pressure	1.0 MPa

Dimensions

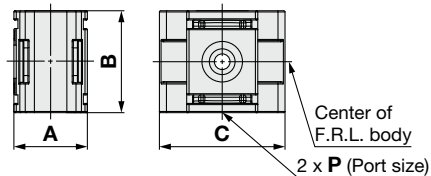

Model	P	A	B	C	Applicable AC size
E200T-D	1/8, 1/4	28	35	42	AC20-D
E300T-D	1/8, 1/4, 3/8	31	43	53	AC30-D
E400T-D	1/4, 3/8, 1/2	39	51	71	AC40-D

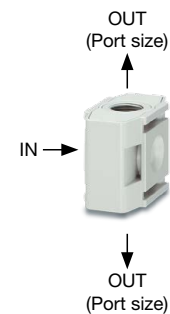
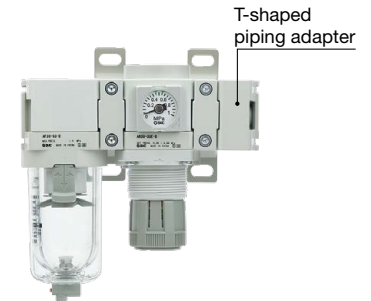

	Port size
IN	—
OUT	③

Caution on Mounting

Pipe threads are not provided on the face which connects with the other components. For use, a separate spacer (or spacer with bracket) is required.

T-Spacer: 1/8, 1/4, 3/8, 1/2, 3/4

· Using a T-spacer facilitates the branching of air flow.

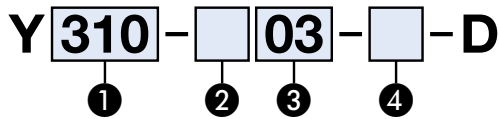

	Symbol	Description	①		
			Body size [Applicable AC size]		
			210 [AC20]	310 [AC30]	410 [AC40]
② Pipe thread type	Nil	Rc	●	●	●
	N	NPT	●	●	●
	F	G	●	●	●
+					
③ Port size (OUT ①)	01	1/8	●	●	—
	02	1/4	●	●	●
	03	3/8	—	○*1	●
	04	1/2	—	—	○*1
+					
④ <small>Sensor body</small> Body type	Nil	Standard	●	●	●
	1	Slim	●	●	●

*1 ○: Only applicable to the standard type body

Standard Specifications

Fluid	Air
Ambient and fluid temperatures	-5 to 60°C (No freezing)
Proof pressure	1.5 MPa
Max. operating pressure	1.0 MPa

Dimensions

Body type: Standard

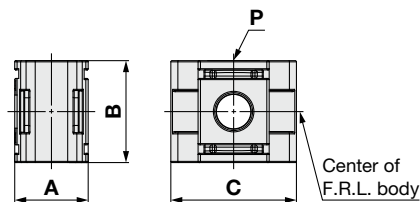

Model	P	A	B	C	Applicable AC size
Y210-D	1/8, 1/4	28	35	42	AC20-D
Y310-D	1/8, 1/4, 3/8	31	43	53	AC30-D
Y410-D	1/4, 3/8, 1/2	39	51	71	AC40-D

Body type: Slim

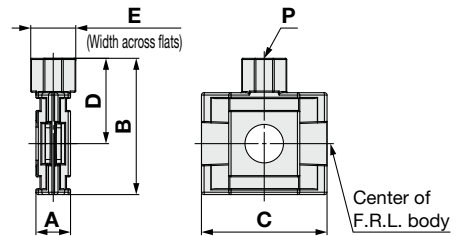

Model	P	A	B	C	D	E	Applicable AC size
Y210-1-D	1/8, 1/4	14.6	48.5	42	31	19	AC20-D
Y310-1-D	1/8, 1/4	14.6	57.5	53	36	19	AC30-D
Y410-1-D	1/4, 3/8	18.6	67	71	41.5	24	AC40-D



Body type: Standard (Y□-□□-D)

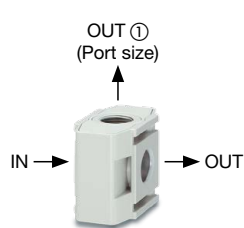

	Port size
IN	—
OUT	—
OUT ①	③

Body type: Slim (Y□-□□-1-D)

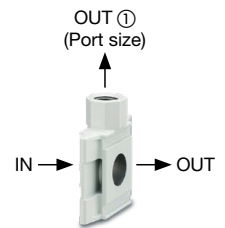

	Port size
IN	—
OUT	—
OUT ①	③

Caution on Mounting

- Pipe threads are not provided on the face which connects with the other components. For use, a separate spacer (or spacer with bracket) is required.
- When the slim body type is to be mounted to a wall using a spacer with bracket, use a spacer on only one side.

NMG Series

Reducing Adapter

- Allows for modular connection with products 1 body size larger or smaller

E 310 R-D

- Reducing adapter
- Body size

310	For connecting sizes 20 and 30
410	For connecting sizes 30 and 40

Standard Specifications

Fluid	Air
Ambient and fluid temperatures	-5 to 60°C (No freezing)
Proof pressure	1.5 MPa
Max. operating pressure	1.0 MPa

Dimensions

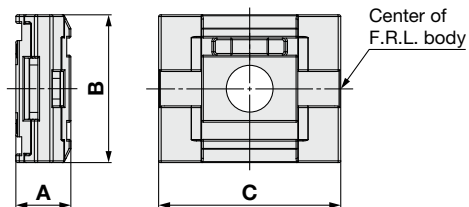

Model	A	B	C	Applicable AC size
E310R-D	16	43	53	AC20-D, AC30-D
E410R-D	20	51	71	AC30-D, AC40-D

Caution on Mounting

- Pipe threads are not provided on the face which connects with the other components. For use, a separate spacer (or spacer with bracket) is required.
- When mounting to a wall using a spacer with bracket, use a spacer on only one side.

Spacer / Spacer with Bracket

Spacer
Y200-D
Y300-D
Y400-D



Spacer with bracket
Y200T-2-D
Y300T-2-D
Y400T-1-D



Standard Specifications

Fluid	Air
Ambient and fluid temperatures	-5 to 60°C (No freezing)
Proof pressure	1.5 MPa
Max. operating pressure	1.0 MPa

Replacement Parts

Description	Material	Part number		
		Y200-D Y200T-2-D	Y300-D Y300T-2-D	Y400-D Y400T-1-D
Seal	HNBR	Y220P-050S	Y320P-050S	Y420P-050S

Dimensions

Spacer

Spacer with bracket

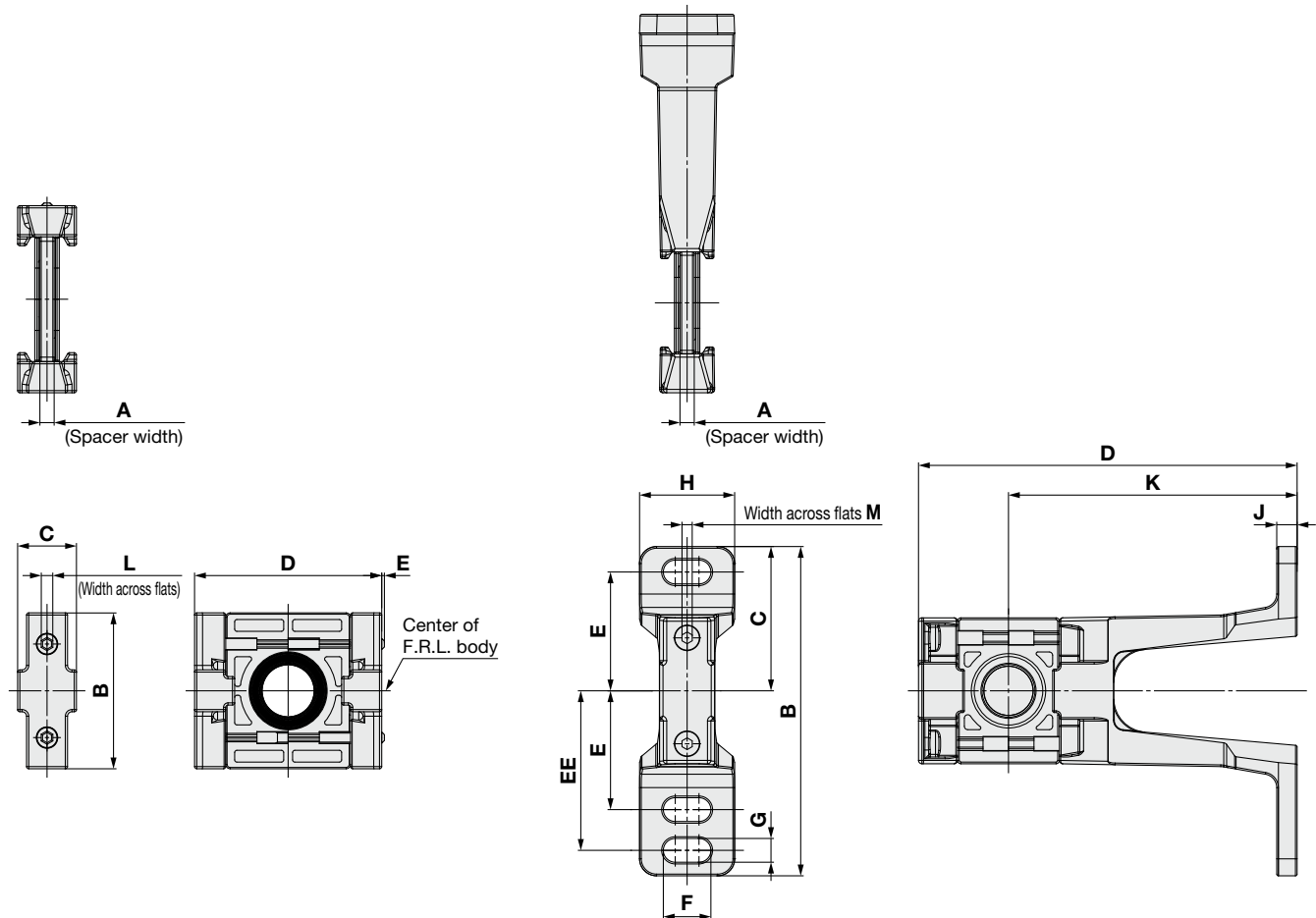

Model	A	B	C	D	E	L	Applicable size
Y200-D	3.2	35	13.2	42	0.6	2	AC20-D
Y300-D	4.2	43	16.2	53	—	3	AC30-D
Y400-D	5.2	51	19.2	71	—	3	AC40-D

Model	A	B	C	D	E	EE	F	G	H	J	K	M	Applicable size
Y200T-2-D	3.2	97	42.5	106	35	47	14	7	28	6	85	2	AC20-D
Y300T-2-D	4.2	97	42.5	111.5	35	47	14	7	28	6	85	3	AC30-D
Y400T-1-D	5.2	115	50	120.5	40	55	18	9	32	7	85	3	AC40-D



NMG Series

Specific Product Precautions

Be sure to read this before handling the products. Refer to the back cover for safety instructions. For air preparation equipment precautions, refer to the “Handling Precautions for SMC Products” and the “Operation Manual” on the SMC website.

Design / Selection

Warning

1. The outlet air is nitrogen-enriched air. Do not use it for breathing air as it may cause lack of oxygen and asphyxiation. Use in a well-ventilated area and ventilate while the product is in use.
2. The purge air is oxygen-enriched air. Use away from fire and combustible materials to avoid fire or explosion. Ventilate the room while the product is in use.

Caution

1. “Nitrogen concentration” in this catalog refers to the total concentration of all components other than oxygen in compressed air. Compressed air contains argon, carbon dioxide, and water vapor in addition to nitrogen and oxygen.
2. Supply sufficient inlet air flow rate. Air supply capacity must be greater than or equal to the required outlet air flow rate plus the purge air flow rate. Insufficient inlet air flow will not provide the required outlet air flow and performance.
3. It takes time to reach the required nitrogen concentration after compressed air is supplied. The time to reach the target concentration depends on conditions and nitrogen concentration, with higher nitrogen concentrations requiring more time. Especially, it may take more than 30 minutes (for reference) for the nitrogen concentration to reach 99.9%.

Mounting / Piping

Warning

1. Handle with care. This product is heavy, and dropping it may cause bodily injury or damage to the product. It is recommended that two or more people mount it.
2. For installation, please use the spacer with bracket (Y300T-2-D, Y400T-1-D).
Connect our spacer with bracket (Y300T-2-D, Y400T-1-D) to both inlet and outlet sides of the product and fix it to the wall. When fixing to the wall, fix the top and bottom 2 places, total 4 places on both sides. Fixing only one side may cause failure of the spacer with bracket. When piping steel pipes, use piping adapters (E300-(F, N)02 to (F, N)04-D or E400-(F, N)02 to (F, N)06-D).
3. Connect the product ensuring the direction of “1” (IN) and “2” (OUT) for air direction and indicated arrow. Incorrect connections may cause malfunction.

Air Supply / Operating Environment

Caution

1. Compressed air purity class [1:6:1] or better according to ISO 8573-1:2010 is recommended for the inlet side compressed air. Mount air preparation equipment (AFF, AMH, AMK) according to the air purity class of the compressed air on the inlet side. If the inlet air contains solid foreign matter or oil, performance will be reduced or the product will be damaged.
2. Remove water droplets from the inlet air. If water droplets flow into the product, the performance may lower, causing malfunction.
3. The pressure dew point of the supply air should be lower than the ambient temperature.
If the dew point is higher than the ambient temperature and flows into the product, it will be cooled inside and condensation will occur, leading to water droplet inflow. Especially, cold environments where the ambient temperature is below 10°C, be careful of freezing and dew condensation.

Safety Instructions

These safety instructions are intended to prevent hazardous situations and/or equipment damage. These instructions indicate the level of potential hazard with the labels of “**Caution**,” “**Warning**” or “**Danger**.” They are all important notes for safety and must be followed in addition to International Standards (ISO/IEC)*1), and other safety regulations.

 **Danger :** **Danger** indicates a hazard with a high level of risk which, if not avoided, will result in death or serious injury.

 **Warning:** **Warning** indicates a hazard with a medium level of risk which, if not avoided, could result in death or serious injury.

 **Caution:** **Caution** indicates a hazard with a low level of risk which, if not avoided, could result in minor or moderate injury.

*1) ISO 4414: Pneumatic fluid power - General rules and safety requirements for systems and their components
ISO 4413: Hydraulic fluid power - General rules and safety requirements for systems and their components
IEC 60204-1: Safety of machinery - Electrical equipment of machines - Part 1: General requirements
ISO 10218-1: Robots and robotic devices - Safety requirements for industrial robots - Part 1: Robots etc.

Warning

1. The compatibility of the product is the responsibility of the person who designs the equipment or decides its specifications.

Since the product specified here is used under various operating conditions, its compatibility with specific equipment must be decided by the person who designs the equipment or decides its specifications based on necessary analysis and test results. The expected performance and safety assurance of the equipment will be the responsibility of the person who has determined its compatibility with the product. This person should also continuously review all specifications of the product referring to its latest catalog information, with a view to giving due consideration to any possibility of equipment failure when configuring the equipment.

2. Only personnel with appropriate training should operate machinery and equipment.

The product specified here may become unsafe if handled incorrectly. The assembly, operation and maintenance of machines or equipment including our products must be performed by an operator who is appropriately trained and experienced.

3. Do not service or attempt to remove product and machinery/equipment until safety is confirmed.

1. The inspection and maintenance of machinery/equipment should only be performed after measures to prevent falling or runaway of the driven objects have been confirmed.
2. When the product is to be removed, confirm that the safety measures as mentioned above are implemented and the power from any appropriate source is cut, and read and understand the specific product precautions of all relevant products carefully.
3. Before machinery/equipment is restarted, take measures to prevent unexpected operation and malfunction.

4. SMC products cannot be used beyond their specifications. They are not developed, designed, and manufactured to be used under the following conditions or environments. Use under such conditions or environments is not allowed.

1. Conditions and environments outside of the given specifications, or use outdoors or in a place exposed to direct sunlight.
2. Use for nuclear power, railways, aviation, space equipment, ships, vehicles, military application, equipment affecting human life, body, and property, combustion equipment, entertainment equipment, emergency shut-off circuits, press clutches, brake circuits, safety equipment, etc., and use for applications that do not conform to standard specifications such as catalogs and operation manuals.
3. Use for interlock circuits, except for use with double interlock such as installing a mechanical protection function in case of failure. Please periodically inspect the product to confirm that the product is operating properly.

Caution

SMC develops, designs, and manufactures products to be used for automatic control equipment, and provides them for peaceful use in manufacturing industries.

Use in non-manufacturing industries is not allowed.

Products SMC manufactures and sells cannot be used for the purpose of transactions or certification specified in the Measurement Act of each country. The new Measurement Act prohibits use of any unit other than SI units in Japan.

Limited warranty and Disclaimer/ Compliance Requirements

The product used is subject to the following “Limited warranty and Disclaimer” and “Compliance Requirements”.

Read and accept them before using the product.

Limited warranty and Disclaimer

1. The warranty period of the product is 1 year in service or 1.5 years after the product is delivered, whichever is first.*2)
Also, the product may have specified durability, running distance or replacement parts. Please consult your nearest sales branch.
2. For any failure or damage reported within the warranty period which is clearly our responsibility, a replacement product or necessary parts will be provided.
This limited warranty applies only to our product independently, and not to any other damage incurred due to the failure of the product.
3. Prior to using SMC products, please read and understand the warranty terms and disclaimers noted in the specified catalog for the particular products.

*2) **Suction cups (Vacuum pads) are excluded from this 1 year warranty.**

A suction cup (vacuum pad) is a consumable part, so it is warranted for a year after it is delivered.

Also, even within the warranty period, the wear of a product due to the use of the suction cup (vacuum pad) or failure due to the deterioration of rubber material are not allowed by the limited warranty.

Compliance Requirements

1. The use of SMC products with production equipment for the manufacture of weapons of mass destruction (WMD) or any other weapon is strictly prohibited.
2. The exports of SMC products or technology from one country to another are governed by the relevant security laws and regulations of the countries involved in the transaction. Prior to the shipment of a SMC product to another country, assure that all local rules governing that export are known and followed.

Revision History

- Edition B**
- * A 1300 type has been added for the single membrane module.
 - * A double membrane module has been added.
 - * A manifold has been added.
 - * The number of pages has been increased from 16 to 32.

 **Safety Instructions** Be sure to read the “Handling Precautions for SMC Products” (M-E03-3) and “Operation Manual” before use.